



Contents

- 1 Welcome**
 - Before Starting 1
 - Using the Programming Menu..... 1
 - Using Buttons 2
 - What’s in the Box? 2
 - Important Phone Numbers..... 2

- 2 Getting Started**
 - Getting Started..... 3
 - Setting the Language 5
 - Installing the Paper Roll 5
 - Setting the Date And Time 6
 - Programming the Sales Tax..... 7
 - PC-Based Software..... 8

- 3 Getting To Know the Cash Register**
 - Turning the Register Off and On..... 10
 - Using the Mode Key Area 11
 - About the Displays..... 11
 - Lifting and Lowering the Customer Display 12
 - Adjusting the Touch Screen 12
 - Using the Touch Screen 13

Using Power Saving Mode17
 Using the Cash Drawer18

4 Setting Up Your Cash Register - the Basics

Setting Working Mode.....21
 Setting Alphanumeric Descriptions.....23
 Using Double Wide Characters.....24
 Setting Header Messages and Footer Messages.....25
 Printing Picture Logos on Receipts27
 Printing Options on Receipts28
 Setting Clerk Numbers and Names28
 Using the Clerk System.....30
 Setting X and Manager Passcodes30
 Setting the Machine Number.....32
 Programming Department Keys32
 Programming Department Names and Numbers34
 Setting High Digit Lock-out (HDLO)34
 Programming Department Preset Price35
 Programming Tax Status.....35
 Setting the Group.....35
 Setting Standard, Gallonage or Negative Mode.....35
 Setting Department Type36
 Setting Age Limits36
 Setting the KP.....37
 Programming the Credit Key.....37
 Programming PLU Descriptions.....38
 Programming PLUs without a Barcode Reader39
 Programming PLUs with the Optional Barcode Reader39
 Mapping PLUs to Direct PLU Keys40
 Editing a PLU41
 Deleting a PLU41
 Printing the Program Confirmation Report42
 Before Going to Register Mode42
 Running the Options Dump Report.....43
 Clearing Errors.....43

5 Setting Up Your Cash Register for Restaurant Mode

Setting Restaurant Mode.....	44
Setting Cooking Messages.....	45
Happy Hour Settings	46
Restaurant Reports	46

6 Navigating Your Cash Register Parameters

401 Department Settings	48
402 PLU Settings.....	48
403 Clerk Settings	48
404 Tax Settings.....	48
405 Text Settings	48
406 Options	49
Printing Parameters Settings	49
System Options Settings.....	53
System Configuration Settings.....	55
Return to Machine to Default Settings	56
Options Dump Report	56
407 Others.....	57
411 Direct PLU Setting.....	57
412 Coupon Setting.....	57
413 Discount Setting.....	57
414 HDLO Setting.....	57
415 Cash in Drawer Limit.....	58
416 FC Setup	58
417 Age Limit Setting	58
418 [Credit] Name	58
419 Cooking Message Set	59
420 Happy Hour Setting	59
421 Picture Logo Choice	59
422 Counter /No Setting.....	59
423 PC Communication	60
424 ISP Upgrade	60
425 Version Information	60
426 System Information.....	60

7 Ringing up Sales and Using Training Mode

Ringing up Sales.....	62
Ringing up Sales without a PLU Number	62
Ringing up Sales with a PLU Number	63
Ringing up Sales with a Direct PLU Key	63
Ringing up Sales with the Optional Royal Barcode Reader	64
Printing Receipts.....	64
Receipt on Demand	65
Using Tables	65
Opening and Closing Tables.....	65
Transferring Tables.....	66
Viewing Active Tables	66
Using Cooking Messages	67
Printing the Bill	67
Closing Out or Ending Tables.....	68
Using Training Mode	68
Setting the Training Passcode	69
Entering and Exiting Training Mode.....	70

8 Programming Complex Tax Rates

About Tax Systems.....	71
USA Tax - Choosing Straight Add-On Rate or Table Tax.....	71
Tax Limits	72
Selecting the Tax System	72
Programming Straight Add-on Tax in the United States	73
Programming Table Tax in the United States	74
Calculating Your Tax.....	75
Example Tax Worksheet	77
The Worksheet.....	78
Using Canadian Tax Rates	79
Using VAT Tax Rates	80
Printing a Confirmation Report	80

9 Running Reports

Running the Department Confirmation Report	82
--	----

Running the PLU Confirmation Report	82
Running the Clerk Confirmation Report	82
Running Management Reports	83
About X Reports.....	83
About Z Reports.....	85
Running Reports	86
Financial Report Example.....	86
More Information about the Electronic Journal (EJ) Reports	88
10 Maintenance and Options	
Cleaning the Touch Screen.....	91
Installing a Replacement Paper Roll	91
About the Serial Port.....	92
Connecting the Cash Register to a PC	93
About the Battery.....	94
11 Troubleshooting	
Paper End or Other Printer Errors.....	95
No Receipt Printing.....	95
No Printing on the Receipt	96
The Cash Register Screen goes Dark	96
Electronic Journal Memory Errors	96
The Cash Register Does Not Work at All	97
Opening the Cash Drawer When There is no Power	97
Performing a Partial Reset.....	98
Performing a Master Reset.....	98
If Nothing Helps	98
Error Messages	99
12 Examples	
Transaction Codes.....	103
Sample Receipt.....	104
Adding Tax to a Non-Taxable Department.....	104
Active Table Pickup	105
Bill Print	105
Cash Sale With Tendering Change.....	105

Cash Sale Without Tendering Change	105
Charge Sale	106
Credit/Charge Refund	106
Check Sale	106
Cooking Messages	107
Using Preset Messages	107
Using Manual Messages.....	107
Coupon Discount Sale	107
Credit Sale	108
Dept Shift Button and Departments above 40	108
Direct (Hard) PLUs	109
Exempting Tax On An Item	109
Exempting Tax on the Entire Sale.....	109
Foreign Currency Sale.....	110
Gallonage Sales Transaction.....	110
Minus Percentage Discount Sale	110
Misc. Sale.....	111
Multiplication of a Department Unit Price	111
Multiplication Sale and Overriding a Preset Department Price.....	112
Multiplying By A Fraction	112
No-Sale Function (Opening the Cash Drawer).....	112
Opening and Closing Tables	113
Paid-Out Sale.....	113
PLU Sale.....	113
Plus Percentage Sale	114
Received-On-Account Sale.....	114
Registering a Department Unit Price.....	114
Registering a Reference Number/Message.....	115
Return Sale	115
Refunding Cash	116
Split Tendering Sale.....	116
Transferring Tables.....	116
Using the Error-Correct /Void Button.....	117
Voiding a Department Preset Price.....	117

Voiding a Multiplication of a Department Preset Price	118
Voiding a Department Multiplication Sale.....	118
Voiding a PLU Sale	118
Voiding a PLU Multiplication Sale	119
Voiding an Entire Sale before Finishing the Sale	119
Voiding a Sale	119
Product Information	
Specifications and Safety.....	121
Safety and Legal Notices	122
CAUTIONS AND WARNINGS	122
Software Licensing Agreement.....	124
Manufacturer’s Limited Warranty.....	125
Ordering Supplies and Accessories	127
Index	128

Welcome

Congratulations on purchasing your new Royal cash register! This register is designed to be easy to use, helping you to focus on running your business.

Before Starting

Before you start using this manual to set up and customize your cash register, you should know the information in this chapter.

Using the Programming Menu

This cash register has a touch screen. You perform most cash register functions by simply touching the correct key on the screen or using the corresponding menu.

The easy menu system on this cash register prompts you through many tasks you perform.

Using Buttons

When you need to press a key in this manual, a picture of the key you need to press appears and the name of the key is in another font. For example:



1 If you are ringing up a check, press **check**.

What's in the Box?

Look for and unwrap the following:

- Cash Register
- Receipt printer
- 1 printer cable to connect the printer to the cash register
- 1 AC power cord to plug the cash register into a wall plug
- RegisterLink™ software and 6 foot serial cable
- 2 sets of keys. 1 set consisting of 2 marked Reg and 2 marked Z Another set of smaller keys to manually lock and unlock the cash drawer.
- 1 starter roll of standard thermal paper, Royal Reorder Number 013127 (2¼ inch or 57.5 mm wide)
- This user's guide and the Quick Start guide
- 3 styluses

Important Phone Numbers

If you need help or want to order additional supplies, use the following contact information.

Customer Service:	1-800-272-6229 (USA)
	1-888-266-9380 (Canada)
	01-800-849-4826 (Mexico)
Ordering Supplies:	1-888-261-4555
Website:	www.royalsupplies.com

To order items, see Ordering Supplies and Accessories on page 127.

Getting Started

Setting up your cash register consists of the following steps:

- 1 Unpacking the cash register
- 2 Connecting the receipt printer and installing the paper roll.
- 3 Plugging the cash register into a power source.
- 4 Turning on the cash register by pressing the power switch on the right side of the cash register

Do all the steps and follow the detailed instructions shown on the cash register display to make sure your cash register is set up correctly.

When you are done with this chapter, see the chapter called Getting To Know the Cash Register, starting on page 10 and the chapter called Setting Up Your Cash Register - the Basics, starting on page 21 for more information about your cash register.

Getting Started

This chapter helps you understand what the setup options are to help you customize the setup.

clear

Note

If you make a mistake while you are programming, press the **Clear** key.

To get the cash register ready to use

- 1** Remove the cash register and the parts from the box. Store the box and packing material in a safe, dry place. If you need to move the register in the future, you can put it back in the box.
- 2** Remove the tape holding the parts of the cash register in place. For example, there may be tape on the Journal Compartment Cover. Put the register on a hard, level surface, away from rain and spilled drinks. A hard, level surface makes it easier for the cash drawer to go in and out smoothly.
Do not put the register on a porous surface. Depending on the surface or any cleaning solution used on the surface, the rubber feet may leave marks on the surface. Do not place the register on any valuable surface, such as antique or fine wood tables, desks, and so on.
- 3** Using the cables provided, connect the receipt printer to the back of the cash register. Connect the other end of the cable to the receipt printer.
- 4** Plug the cash register into a grounded three-hole electrical wall outlet. (115-120 volt, 60 hertz). Make sure the electrical cord is not going to be tripped over or accidentally pulled from the electrical outlet.
Put the cash register on an electrical circuit with no other electrical device or appliance. Other appliances can overload the circuit or cause electrical interference with the cash register. It is best that you use a circuit without other appliances already on it.
- 5** Using the switch located on the right side, turn the cash register on. You see a system message and then a prompt.
- 6** Using the included stylus, carefully press the dots on the upper left and then the lower right corners of the screen. The cash register is ready to use in Restaurant mode.

Caution

The cash register initially starts in Restaurant mode. You can change this to Retail mode, if needed. If you change your mind later, changing modes deletes all programming you entered. For more information about programming the mode, see Working Mode on page 56.

Setting the Language

You can select the cash register to use English, Spanish, or French.

Important

Not all versions of the cash register support multiple languages. Contact Royal at 1-800-243-4002 with any questions.

Changing the language changes the factory programmed words you and the customer see on the displays. However, changing the language does not translate any words you program in the cash register, such as PLU descriptions, header information, and so on.

Note

If you start programming the cash register and then change the language, you lose all your programming changes.

To set the language when you first set up the cash register

406 -- Options ▶ System Options Settings

- 1 Put the MGR key in the Mode key slot and turn it to the PROG position.
- 2 Press the **Arrow Down** key to select 406 -- Options. Press **Enter**.
- 3 Press the **Arrow Down** key to select System Options. Press **Enter**.
- 4 Select System Configuration Settings. Press **Enter**.
- 5 Select Language. Press **Enter**.
- 6 Select the language you want using the pop-up box. The language shown on the displays is set to the language you selected.

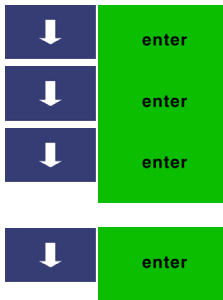
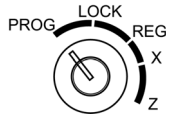

Installing the Paper Roll

Your cash register has a separate thermal printer that prints receipts for the customer. Use 2¼ inch (57.5 mm) wide standard thermal register paper. Do not use bond paper because the register does not use a ribbon or ink for printing.

Caution

Do not manually pull the receipt paper. Always use press the **Feed** key to remove or advance the paper. Do not use sharp or pointed instruments in the printer. This can seriously damage the printer.



To install the paper roll

- 1 Open the receipt printer cover.
- 2 Unwrap the paper roll. Place the paper roll in the paper well with the paper feeding from the bottom.
- 3 Grab the small handle on the right of the print head. Flip the little handle towards the front of the printer.
- 4 Feed the end of the paper into the slit under the print head.
- 5 Flip the little handle towards the back of the printer.
- 6 Press the **Feed** key to move the paper through the printer to make sure there is no jam and the paper is properly installed before continuing.
- 7 Feed the paper through the paper slot in the printer cover.
- 8 Close the printer cover.

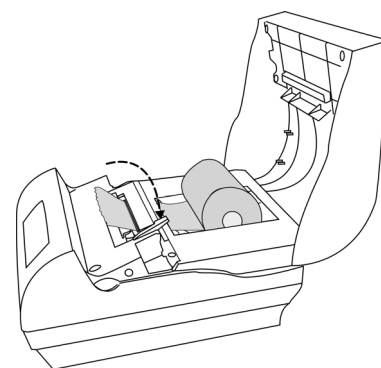
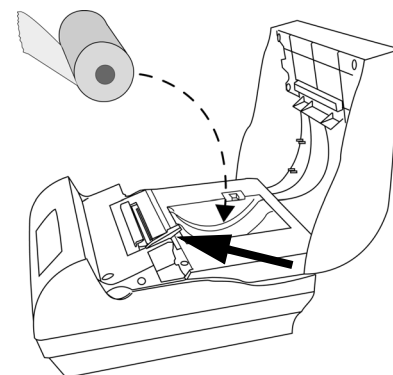

feed

Setting the Date And Time

The date changes every day and prints in the month-day-year format. You can prevent the date from printing on the transaction receipts. The date format can also be changed to print day-month-year. For more information, see Date Format on page 55.

The time can print in either the 12 or 24 hour (military time) format. The default setting is to print in the 12 hour format, which is normally used. To change to the 24 hour format, see Date Format on page 55. You can set the cash register so that it does not print the time on receipts. For more information, see Printing Options on Receipts on page 28.

To set the date

406 -- Options ▶ System Configuration Options

- 1 Put the MGR key in the Mode key slot and turn it to the PROG position.
- 2 Press the **Arrow Down** key to select 406 -- Options. Press **Enter**.
- 3 Select System Configuration Settings. Press **Enter**.
- 4 Select Date Adjust. Press **Enter**. Press the **Enter** key again.

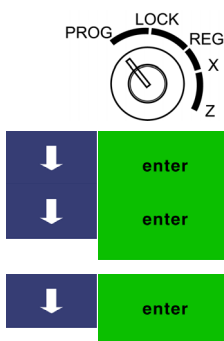

- At the prompt, use the Number keys to enter the date.

For example, to enter June 30 2007, press 063007. Press **Enter**.

To set the time

406 -- Options ▶ System Configuration Options

- Put the MGR key in the Mode key slot and turn it to the PROG position.
- Press the **Arrow Down** key to select 406 -- Options. Press **Enter**.
- Select System Configuration Settings. Press **Enter**.
- Select Time Adjust. Press **Enter**. Press the **Enter** key again.
- At the prompt, select AM or PM.
- At the prompt, use the Number keys to enter the date.

For example, to enter 9:43 am, press 0943. Press **Enter**.

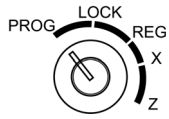

Programming the Sales Tax

Now you need to select and program the sales tax for your area. You can use 1 of 2 tax types in the US:

- Straight tax:** The sales amount is multiplied by a flat percentage rate such as 5%. For example, on a \$1.00 item, \$.05 is added for tax.
- Table tax:** The tax is charged based on a tax table you obtain from your local or state government tax office.

Straight tax is the easiest and most commonly used tax rate. Most states and areas use straight tax. To find out which sales tax type and percentage rate to use, contact your local government office.

You can also set the the *maximum non-taxable amount* (the highest amount at which taxes are exempt) or *tax limit*.

This section explains setting simple sales tax in the United States, the default. See *Selecting the Tax System* on page 72 for other sales tax systems.

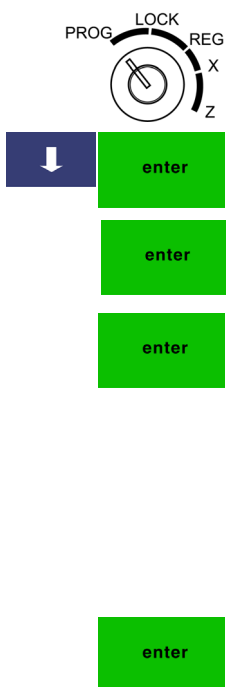

To set Straight USA (add-on tax)

404 -- Tax Settings

- 1 Put the MGR key in the Mode key slot and turn it to the PROG position.
- 2 Press the **Arrow Down** key to select 404 -- Tax Setting. Press **Enter**.
- 3 Select Tax 1 Setup and press **Enter**. Select Rate.
- 4 Press **Enter**. Enter the tax rate. For example, if your local sales tax rate is 10%, enter 10000. To program other tax rates, press the following:

For this tax rate...	Press these keys...
7.75%	7750
5.5%	5500
10.5%	10500

- 5 Press **Enter**. For tax tables and more advanced tax rate programming, see Programming Complex Tax Rates on page 71.

For more information about the other features of your cash register, see Setting Up Your Cash Register - the Basics on page 21 and Navigating Your Cash Register Parameters on page 47.

PC-Based Software

Your cash register includes:

- RegisterLink PC-based software.
 - This software allows you to connect the cash register to your PC to download your sales information and transfer it to QuickBooks® Pro 2002 or later accounting software. For instructions about using the software, see the RegisterLink manual.
 - Program your cash register from the PC - You can program clerk names, PLUs, departments, the header, and the footer on your PC and download these settings to your cash register.
 - Back-Up and Restore - Whether you programmed your cash register data on the cash register or on your PC, you can back-up that programming and store the data on your PC. Should you lose the memory in your cash register, you can simply restore the data from your PC back to the cash register without having to reprogram all the PLU's, Departments and other data.
 - Additional Cash Registers - When you buy additional cash registers, you can use the back-up-and-restore feature with multiple registers of the same model number. Just program one register, back-up the data to your PC, and then restore or download the data from your PC to the other

registers, as long as they are all the same model number. This saves you the time of having to program each register individually.

Check the Royal web site for any new features and upgrades to RegisterLink.

Using the RegisterLink software requires connecting your computer to the cash register using the serial port. To connect your computer to the serial port, you need to use the included null-modem serial cable. For technical details about the serial connection, see *About the Serial Port* on page 92.

For information for connecting the cash register to your PC, see *Connecting the Cash Register to a PC* on page 93.

The RegisterLink software is on a CD. Please install the software from this CD. Then check for updates on the Royal web site (www.royalsupplies.com). If a later version of the RegisterLink software is available on the website, download it from the web site and install it on your PC. It is important that the CD version of the software is already installed on your PC before you download and install any updates.

RegisterLink software instructions are separate from this manual. The RegisterLink instruction manual is on the CD that contains the software. An updated and revised version of the instruction manual accompanies any newer version of the software that is downloaded from our web site. Refer to the RegisterLink instruction manual for all software-related operational instructions and assistance.

Getting To Know the Cash Register

This chapter shows you the basics of using your cash register after you set it up. If you have not yet set up your cash register, see the Quick Start sheet that came in the box with your cash register or Getting Started on page 3.

Turning the Register Off and On

You should turn the cash register off when you are not using it. The touch screen does not work and the cash drawer is electronically locked. A small amount of power maintains the programming and transaction data totals.

Note

Do not turn the cash register off in the middle of a transaction. Complete all transactions before you turn the cash register off. If the cash register is turned off during a transaction, when the cash register is turned on again, you see a message that the power was interrupted. Depending on the control lock position, you may or may not see a "Transaction did not end" message.

To turn the cash register on

- 1 Locate the power switch on the right side of the cash register.
- 2 Press the switch towards the back of the cash register to turn it ON.

To turn the cash register off

- 1 Locate the power switch on the right side of the cash register.
- 2 Press the switch towards the front of the cash register to turn it OFF.

Using the Mode Key Area

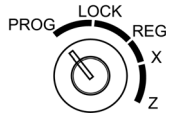

In the Mode key area you can do the following.

Table 1 Mode key settings

This setting...	Does this...
• PRG	Programs the cash register. Use the key marked MGR.
• LOCK	Locks the cash register and shows the screen saver. All keys do this.
• REG	Turns the cash register ON for all normal sales transactions. All features of the cash register are activated as programmed. A customer receipt is printed for every transaction, if the cash register is programmed to do this.
• X	Lets you read all transaction totals without clearing any totals. This is useful for mid day reports. Use the key marked MGR.
• Z	Lets you read all transaction totals and clears all transaction totals to zero, except the end of day, or close of day, totals. Use the key marked MGR.

If you need to keep the register plugged in when you are not using it, turn the Mode key to the LOCK position. The touch screen will not work and the cash drawer is electronically locked. A small amount of power maintains the program and transaction data totals.

About the Displays

Your cash register has 2 displays.

Clerk screen

Your cash register has a touch LCD screen. This screen lets you touch the “keys” on the screen to program the cash register, ring up sales, and generate reports.

Using the adjustment flap on the back of the screen, you can move the screen to 6 different positions to make it easier for you to use.

Customer Display

You can lift and rotate the customer display so customers can see what is happening. When you move the register or store it, lower the display so it doesn't get damaged.

Your cash register has a 1 line customer display that shows letters and numbers (alphanumeric) The alphanumeric display shows 10 digits for descriptions and sales dollar amounts.

Lifting and Lowering the Customer Display

You can lift and lower the customer display so that customers can easily see what is happening.

Adjusting the Touch Screen

Your cash register has an LCD touch screen for the operator. You can adjust the angle of the clerk display to more easily see the screen. The screen can adjust to one of 6 angles.

To adjust the clerk display

- 1** Lift the touch screen. Do the following:
 - a** Grasping the upper right and left sides of the touch screen, lift the touch screen away from the cash register.
 - b** The touch screen rotates from the bottom.
 - c** Do not force the touch screen past the maximum position.
- 2** Move the adjustment flaps away from the cash register. Do the following:
 - a** Look at the back of the screen.
 - b** Grasping the legs of the adjustment flap, move the adjustment flap away from the touch screen.
 - c** The adjustment flap is attached at the top of the touch screen.
- 3** Place the legs of the adjustment flap in the slots. Do the following:
 - a** Look in the recessed area that the screen was folded into.
 - b** Locate the slots.
 - c** Place the legs in a slot.
 - d** Try the different slots until you like the angle of the touch screen.
- 4** Gently press down on the touch screen to make sure it is seated firmly in place.

Using the Touch Screen

The restaurant touch screen on your cash register looks similar to the following:

<R> clerk01				feed	RA	PO	Discount %	coupon	trans void
↑	page up	page down	↓	void	R.M	E.C.	refund	transfer table	C.M
THE RIVER GRILL 222 West Main Street Hoboken, NJ 87988 SNOW CRAB 21.95 LOBSTER 29.95 MIXED GREENS 9.99 ARUGULA SALAD 8.95 CLAM CHOWDER 6.00 FILET MEDIUM 17.95 FILET RARE 17.95 BAR TOTAL 54.00				appetizers	salad	soup	seafood	entree	active table
				dept	#/ns	tax 1	tax 2	shift	plu
					non tax	tax 3	tax 4	bill print	
				clear	x/time	clerk	fce	hard plu	
7	8	9	misc	open table	close table				
4	5	6	credit	subtotal					
subtotal	112.74	1	2	3	charge	amount tender			
TOTAL	166.74	0	00	.	check				

The retail touch screen on your cash register looks similar to the following:

<R> clerk01				feed	RA	PO	Discount %	coupon	trans void
↑	page up	page down	↓	void	R.M.	E.C.	refund	registers	supplies
ROYAL CONSUMER INFORMATION PRODUCTS INC 379 Campus Drive P.O. Box 6786 Somerset, NJ 08875 USA 732.627.9977 telephone www.royal.com SHREDDER 1 89.99 CALCULATOR 1 6.99 TAX 1 6.79				shredders	cameras	phones	calcs	scales	sharpener
				dept	#/ns	tax 1	tax 2	dept shift	plu
					non tax	tax 3	tax 4		
				clear	x/time	clerk	fce	hard plu	
7	8	9	misc	subtotal					
4	5	6	credit	subtotal					
subtotal	2	96.98	1	2	3	charge	amount tender		
TOTAL	103.77	0	00	.	check				

To use the touch screen, do the following:

- To use the cash register, put the Reg key in the Mode key slot and turn it to the Reg position. Now you can press the Number keys and Department keys to ring up a sale. For more information about ringing up sales, see Ringing up Sales and Using Training Mode on page 61.
- To program the cash register, put the MGR key in the Mode key slot and turn it to the PROG position. You can start programming. For more information about programming the cash register, see Setting Up Your Cash Register - the Basics on page 21 and Navigating Your Cash Register Parameters on page 47.

7	8	9
4	5	6
1	2	3
0	00	.

The following identifies some of the keys on the touch screen and what you can use them for

Table 2 Navigating the touch screen



To do this...	Use this key...
Enter single entry coupon discounts	
Feed paper through the printer	
Use Received On Account	
Use one of three preset discounts or add-ons	
Return Merchandise	
Use Cash Paid-Out	
Apply one of four Foreign Currency options	

Table 2 Navigating the touch screen



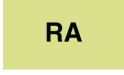
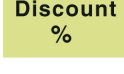
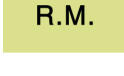
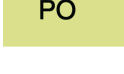
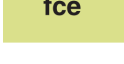

To do this...	Use this key...
Error Correction of last input.	
Access up to 240 direct or hard PLUs for one-touch item entry	
Enter a PLU number manually	
Clear an entry	
Enter multiple quantities of a PLU or item during a sale	
Show the default date/time/status screen on the clerk display between sales in the Sales Registration mode	
<p>Sets an entire sales transaction as tax exempt, if pressed after the Subtotal key at the end of a transaction. For example, you might be selling to a non-profit organization or a reseller.</p> <p>No further items can be entered if a sale is set to tax-exempt. You see a prompt on the clerk screen to help you</p> <p>If pressed before an item is entered, it overrides the tax on that item.</p>	
Override the pre-programmed tax rate for an item with a different tax rate	

Table 2 Navigating the touch screen



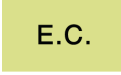



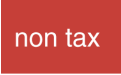
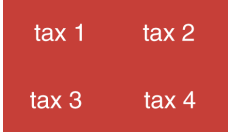







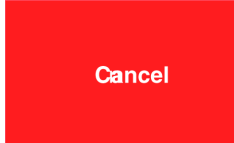

To do this...	Use this key...
Scroll up and down on the screen	   
Exit the current screen and go back to the previous screen	
Refund	
Received on account	
Enter a descriptive or reference number during a sale, such as an invoice number or product serial number	
In Restaurant mode, enter a manual cooking message	
Open the cash drawer and ring a No-Sale transaction	
Void a line item, a specific amount, or a PLU entry	
Void entire current sales transaction	
Log on or log off a clerk	

Table 2 Navigating the touch screen

To do this...	Use this key...
End a sale as a Charge sale paid for by a credit card	
End a sale as a Credit sale paid for by a credit card	
Enter a character as double-wide during text and description entries in Programming mode	
Subtotal a sales transaction	
End a sale paid for with check or money order	
End a sale paid for with cash	
Enter the dollar amount the customer gave you for a cash sale and the register calculates change	
Reprint the sales receipt for the previous sales transaction before another transaction is started	
To enter and accept all entries in the Program mode and Reports mode	

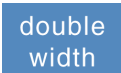
Using Power Saving Mode

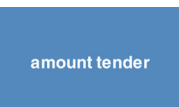
The cash register includes a power saving, or “sleep” mode. This mode saves energy and prevents the clerk display from getting damaged by “burn-in”—just like a screen saver on your laptop or PC.

After a specified period of minutes of inactivity, the cash register goes into sleep mode and the clerk display goes dark. The cash register does not actually turn all the way off, it just goes to sleep.

To wake up the unit, tap the touch screen.

Note

If you have a barcode reader attached, you cannot wake the cash register up using the barcode reader. You must touch the screen.

The default time before the cash register goes to sleep is 5 minutes, but you can change this.

To change the power saving time

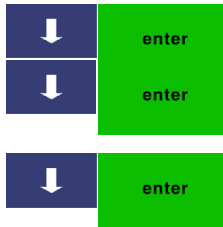
406 -- Options ▶ System Configuration Setting ▶ Power Saving

- 1 Put the MGR key in the Mode key slot and turn it to the PROG position.
- 2 Press the **Arrow Down** key to select 406 -- Options. Press **Enter**.
- 3 Press the **Arrow Down** key to select System Configuration Setting. Press **Enter**.
- 4 Press the **Arrow Down** key to select Power Saving. Press **Enter**.
- 5 Touch your selection.

Using the Cash Drawer

The cash drawer is where you put the money after you ring up a sale. Inside the cash drawer is the cash tray. The cash tray has slots for putting paper bills and a removable tray for coins. You can store paper items such as checks and charge slips under the removable coin tray.

The cash drawer also has 2 media slots on the front of the cash drawer that let you slide paper items, such as checks into the cash drawer without opening the cash drawer. When you slide items into the media slots, the items are automatically placed under the cash tray. Lift the cash tray out of the cash drawer to retrieve these items.

When you ring up a sale, the cash drawer automatically opens so you can make change and put money away. You can also electronically open the cash drawer without making a sale. This is handy if you need to make change for someone or forgot to put something away. Press the **#/NS** key.



The cash drawer locks in 2 different ways. Locking the cash drawer is a good idea if you need to leave the cash register.

- The cash drawer automatically locks electronically when you turn the cash register off. The emergency open lever will still open the cash drawer when it is electronically locked.
- You can also use the **777** key to mechanically lock the cash drawer. If you lock the cash drawer this way, you must have the key to open it again. Even the emergency open lever will not open the cash drawer when it is locked with the key.

Important

If the cash drawer will not open, see if the lock on the cash drawer is turned to the right. If it is, the drawer is locked with the 777 key. You need the key to unlock the cash drawer. If the key is lost or locked in the cash drawer, contact Royal.

When you are using the cash drawer, make sure you lower the bill arms before you close the cash drawer. Never slam the drawer closed.

To open the cash drawer after a sale

amount tender

- 1 When you are done ringing up a sale, press the **Amount Tender** key or any charge key. The cash drawer opens. You can make change and put the money in the drawer.
- 2 When you are done, push the cash drawer closed.

To open the cash drawer without making a sale

#/ns

- 1 Press the **#/NS** key. The cash drawer opens and a No Sale receipt prints.
- 2 When you are done, push the cash drawer closed. These “no-sale transactions” are recorded in the Electronic Journal and on the X/Y daily sales reports for an audit trail.

To lock and unlock the cash drawer using the key

- 1 Using the small key labeled 777, insert the key in the lock in the front of the cash drawer.
 - To lock the cash drawer, turn the key to the right and remove the key from the lock.
 - To unlock the cash drawer, turn the key to the middle position and remove the key from the lock.
- 2 To open the cash drawer manually (for example, if the cash register is unplugged), insert the 777 key and turn to the left. The cash drawer opens.

To open the cash drawer using the emergency lever

- 1** With your hands on the cash drawer, carefully tip the front of the register up. Make sure you support the touch screen. Underneath the cash register, toward the back of the register, you see a small lever.

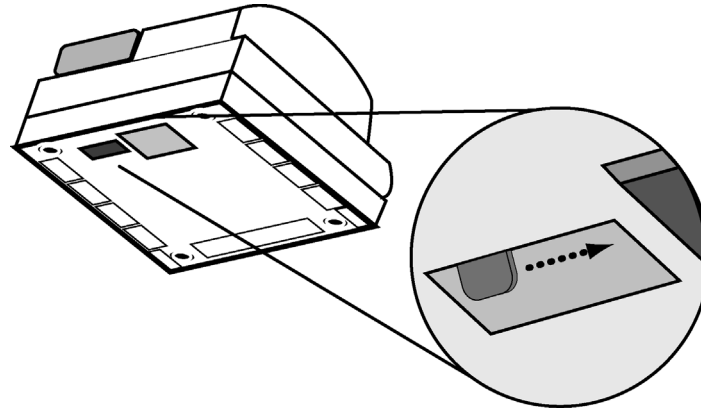

- 2** Push the lever in the only direction it will move. The cash drawer opens. If the cash drawer will not open, make sure it is not locked with the 777 Drawer key.

Setting Up Your Cash Register - the Basics

This chapter includes explanations for:

- Setting working mode
- Specifying messages on the display and on receipts
- Setting clerk names and numbers
- Setting machine numbers
- Setting clerk and manager passcodes
- Programming PLUs
- Clearing error codes
- and more

Setting Working Mode

One of the most important settings you make is selecting the mode you want the cash register to run in. After you select a mode, if you change to the other mode, you lose all your sales and programming information.

This cash register has 2 modes: Restaurant mode and Retail mode.

Restaurant mode - the default

The TS4240 includes specific features that make it easy to run your restaurant, including:

- Table tracking and floating guest checks. This lets you support multiple tables and up to 40 server staff, as well as transferring tables, closing tables and much more.
- Up to 240 of the 3,000 available PLUs can be setup using direct keys. Direct PLUs let you program an item, such as Porterhouse Steak, and assign it a price. When the server staff presses the Porterhouse Steak key, a Porterhouse Steak with the correct price is registered.
- One remote kitchen or bar printer. This lets you include a printer in the kitchen so the cooking staff can print orders.
- Age verification setting. This prompts your staff to check customer identification and verify age requirements for certain orders, such as alcohol. You can specify up to 2 different ages.
- Happy Hour settings. This lets you assign one of the three price levels for PLUs during specified times each day. Then, during that Happy Hour, a discounted price can be in effect. You can also use this for different prices on the same items on a lunch menu and a dinner menu.
- For more information about using the cash register in restaurant mode, see *Setting Up Your Cash Register for Restaurant Mode* on page 44.

Retail mode

The TS4240 includes specific features that make it easy to run your retail business, including:

- Up to 200 Departments. You can program each Department with a name or description of up to 12-characters. Also, program the appropriate tax rate and individual prices. Each department can be set with special features such as gallonage for the sale of measured items, negative department and with an age limit.
- Up to 240 of the 3,000 available PLUs can be setup using direct keys. Direct PLUs let you program an item, such as 8x10 Frame, and assign it a price. When the clerk presses the key labeled 8x10 Frame, a 8x10 Frame with the correct price is registered.
- 40 Clerk ID System. This lets you program clerk access for up to 40 employees. You can specify employee names, up to 24-characters, to print on receipts. This also lets you run sales analysis by clerk. You must specify numeric passcodes for each clerk.

- Age verification setting. This lets prompts your staff to check customer identification and verify age requirements for certain items, such as alcohol or tobacco. You can specify up to 2 different ages, such as 1 for alcohol and 1 for tobacco.
- Multiple Price Levels for each PLU. This lets you assign one of the three price levels for discounted prices or different prices during different times of the day, such as clearance items or end-of-day sales for fresh food, baked goods and other prepared foods.

Caution

Changing modes after you set up your cash register deletes your programming settings. You cannot undelete these settings.

To set the mode

406 -- Options ▶ System Configuration Settings

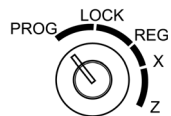

- 1 Put the MGR key in the Mode key slot and turn it to the PROG position. If prompted, enter the Manager passcode and press **Enter**.
- 2 Press the **Arrow Down** key to select 406 -- Options. Press **Enter**.
- 3 Press the **Arrow Down** key to select System Configuration Settings. Press **Enter**.
- 4 Press the **Arrow Down** key to select Working Mode. Press **Enter**.
- 5 Select Retail or Restaurant. If you see a warning prompt, press Yes.

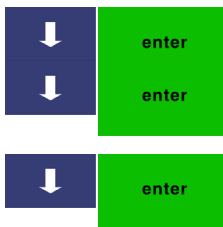

Setting Alphanumeric Descriptions

You can program custom header and footer messages, clerk names, departments, and item descriptions. These text messages and descriptions appear on the receipt and on the customer display.

Note



Only capital letters of the alphabet initially appear on the screen. To use lower case letters, press the **caps lock** key.

Use the Number keys to enter any numbers you want.



You may need certain special symbols. For example, if you need the / symbol or if you need a comma, press the **Symbol** key. There are 2 pages of available symbols.

Important

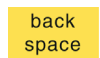

If you enter the wrong character, press the **back space** key to delete the character. Now you can continue.

The maximum number of characters that can be programmed for each item description are shown below.

Department	12 Characters
PLU	12 Characters
Clerk Name	12 Characters
Header and Footer messages	5 Lines (24 characters each)

- For programming text messages that appear on the customer display and the receipt, see Setting Header Messages and Footer Messages on page 25.
- For programming department keys, see Programming Department Keys on page 32.
- For programming PLUs, see Programming PLU Descriptions on page 38.
- For programming Clerk names and numbers, see Setting Clerk Numbers and Names on page 28.

Using Double Wide Characters

For extra emphasis, you can program double wide characters for a specific character or a line of characters.

Normal Size	Double Wide
<pre> * YOUR RECEIPT * * THANK YOU * * ===== Item Name Total ===== APPLE \$1.00 BANANA \$1.00 PEAR \$1.00 ----- SUB \$3.00 ----- Cash \$3.00 Total Qty 3 </pre>	<pre> * YOUR RECEIPT * * THANK YOU * * ===== Item Name Total ===== APPLE \$1.00 BANANA \$1.00 PEAR \$1.00 ----- SUB \$3.00 ----- Cash \$3.00 Total Qty 3 </pre>

If you use double wide characters, the maximum number of characters you can use is reduced by half.

Department	6 Characters
PLU	6 Characters

Clerk Name 6 Characters

Header and Footer messages 5 Lines (12 characters each)

double width

To make a character print extra wide, press the **double width** key before each character as you type in the description. To turn off double width, press the **double width** key again.

Setting Header Messages and Footer Messages

You can specify a header message and/or footer message to print on customer receipts. Each message can be a maximum of 5 lines. Each line can have 24 characters.



is the default printout for the header message.

Make a copy of the blank Worksheet below for future changes or revisions to your header message or footer message.

Header Message or Footer Message Worksheet

Use this worksheet to make your header message or footer message. Make a copy of the blank worksheet before you start, in case you make a mistake or change your mind.

Line 1																							
Line 2																							
Line 3																							
Line 4																							
Line 5																							

back space

Important If you enter the wrong character, press the **back space** key to delete the character. Now you can continue.

The text in the header message and the footer message is automatically centered. If you do not want the message to be centered, enter the rest of the characters as spaces at the beginning or the end of the text to right or left align your text.

Before programming your header or footer message

- 1 Write out your store name and the header message you want to program.
- 2 After writing out your message, count the number of characters on each line.
- 3 Complete the chart, filling in extra unused characters with blank spaces. The text for each line is automatically centered.

Line 1		I	N	T	E	R	N	A	T	I	O	N	A	L		C	O	F	F	E	E	S		
Line 2							9	9	9	-	5	5	5	-	1	2	1	2						
Line 3			2	2	2		E	A	S	T		M	A	I	N		S	T	R	E	E	T		
Line 4						O	P	E	N		7	A	M		T	O		6	P	M				
Line 5			C	O	F	F	E	E	S			O	F		T	H	E		W	O	R	L	D	

Remember, you can make the characters double width but you can only use half the total number of characters if you do this. For example, if you want `Coffee` to be double wide, you need 12 characters. For more information about double wide characters, see [Using Double Wide Characters](#) on page 24.

This is an example of the programmed header message:

```

INTERNATIONAL COFFEES
      999-555-1212
    222 EAST MAIN STREET
      OPEN 7AM TO 6PM
    COFFEES OF THE WORLD
    
```

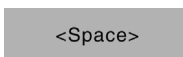

To add a space between words, press the **Space** key.



Important

If you enter the wrong character, press the **Backspace** key to delete the character. Now you can continue.

To program header messages or footer messages

405 -- Text Message ▶ Header Message or Footer Messages

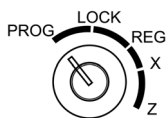

- 1 Put the MGR key in the Mode key slot and turn it to the **PROG** position. If prompted, enter the Manager passcode and press **Enter**.
- 2 Press the **Arrow Down** key to select 405 -- Text Message. Press **Enter**.
- 3 Press the **Arrow Down** key to select Header Message or Footer Message. Press **Enter**.
- 4 Select the line you want to program.

- 5 Follow the instructions on the screen.

Printing Picture Logos on Receipts

You can specify that a logo print on your cash register. The cash register has 10 logos already installed for you to use. You can specify these logos print at the top of the receipt before the header message or at the bottom of the receipt after the footer message. Logos are not set to print by default.

Logos selections are:

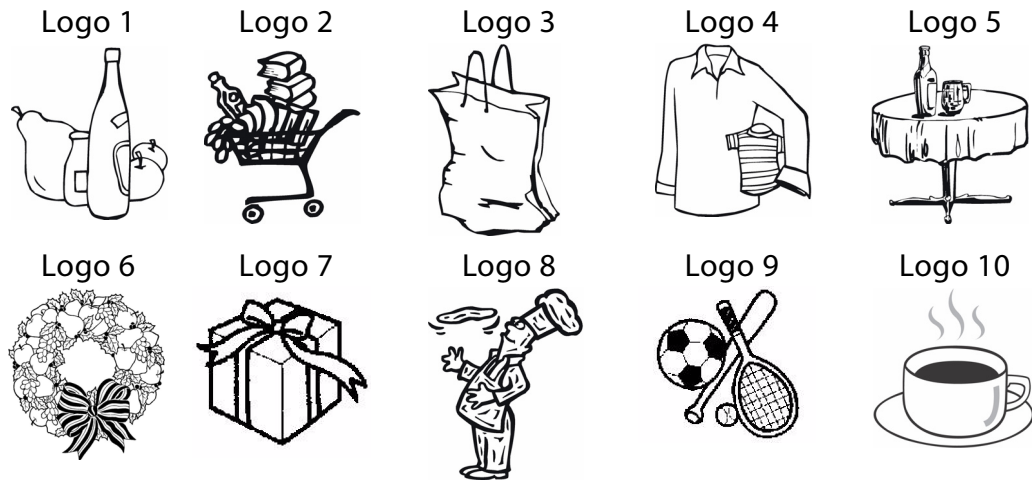

To specify to use a logo

407 -- Others ▶ 421 -- Picture Logo Choice

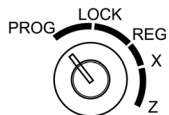

- 1 Put the MGR key in the Mode key slot and turn it to the PROG position. If prompted, enter the Manager passcode and press **Enter**.
- 2 Press the **Arrow Down** key to select 407 -- Others. Press **Enter**.
- 3 Press the **Arrow Down** key to select 421 -- Picture Logo Choice. Press **Enter**.
- 4 A list of numbers appears. Using the list, select the number of the logo you want.
- 5 Now you can specify where you want the logo to print on the receipt. printing at the top of the receipt is the default.

To specify the location of the logo

406 -- Options ▶ Printing Parameters Settings

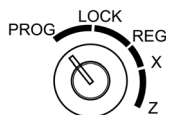

- 1 Put the MGR key in the Mode key slot and turn it to the PROG position.
- 2 Press the **Arrow Down** key to select 406 -- Options. Press **Enter**.

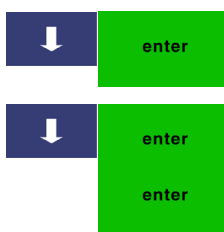

- 3 Press the **Arrow Down** key to select Printing Parameters Settings. Press **Enter**.
- 4 Press the **Arrow Down** key to select Position of Logo Print. Press **Enter**.
- 5 Select Foot or Head and press **Enter**.

Printing Options on Receipts

You can specify if the following prints on receipts:

- Headers and footers
- Clerk names
- Machine number
- Transaction number
- Date and time
- Tax total, amount and location
- Department name or PLU name
- Blank Lines
- Currency symbols
- Barcode numbers

To set receipt printing options

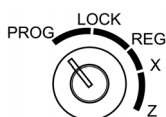

406 -- Options ▶ Printing Parameters Settings

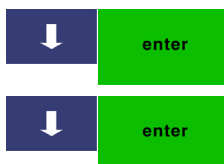

- 1 Put the MGR key in the Mode key slot and turn it to the PROG position. If prompted, enter the Manager passcode and press **Enter**.
- 2 Press the **Arrow Down** key to select 406 -- Options. Press **Enter**.
- 3 Press the **Arrow Down** key to select Printing Parameter Settings. Press **Enter**.
- 4 The options appear on the screen. Scroll to select the one you want. The next sections in this chapter explain the available options.

Setting Clerk Numbers and Names

You can program and assign up to 40 Clerk Names so you can monitor sales by individual employees. Each clerk can also be assigned a 12 character name. If you lose a clerk passcode, you can use the super-clerk passcode. For more information, see Setting X and Manager Passcodes on page 30.

To see the sales totals for each clerk, a Clerk Sales Report is available in both the X and Z modes.

To set use the clerk system:

- 1 Program the clerk names and passcodes.
- 2 Activate the clerk system.
- 3 Set the clerk mode to Compulsory, if needed.

Note

When clerks enter passcodes, passcodes appear as asterisks **** on the display for extra security.

After you are done programming clerk numbers, you can check your results directly on the screen or by printing using 403 -- Clerk Setting ▶ Print Programmed Clerks.

Important

If you enter the wrong character, press the **back space** key to delete the character. Now you can continue.



To set a clerk number and program a name and passcode

403 -- Clerk Setting

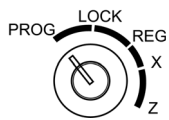

- 1 Put the MGR key in the Mode key slot and turn it to the PROG position. If prompted, enter the Manager passcode and press **Enter**.
- 2 Press the **Arrow Down** key to select 403 -- Clerk Setting. Press **Enter**.
- 3 Press the **Arrow Down** key to select the first clerk name you want to change. Press **Enter**.
- 4 Follow the instructions on the display.

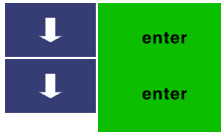

Now you need to set the Clerk System to be active.

To turn on the Clerk System

406 -- Options ▶ System Options Settings

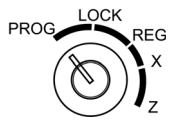

- 1 Put the MGR key in the Mode key slot and turn it to the PROG position. If prompted, enter the Manager passcode and press **Enter**.
- 2 Press the **Arrow Down** key to select 406 -- Options. Press **Enter**.
- 3 Press the **Arrow Down** key to select System Options Settings. Press **Enter**.
- 4 Press the **Arrow Down** key to select Clerk System Active. Press **Enter**.
- 5 Press Yes.

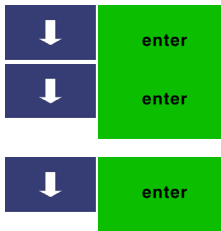

Now you can require that a clerk enter their passcode before every transaction.

To require Clerk passcodes for every transaction

406 -- Options ▶ System Options Settings

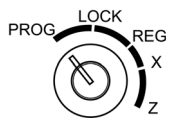

- 1 Put the MGR key in the Mode key slot and turn it to the PROG position. If prompted, enter the Manager passcode and press **Enter**.
- 2 Press the **Arrow Down** key to select 406 -- Options. Press **Enter**.





- 3 Press the **Arrow Down** key to select System Options Settings. Press **Enter**.
- 4 Press the **Arrow Down** key to select Compulsory Clerk Declaration. Press **Enter**.
- 5 Press Yes.

Using the Clerk System

If the clerk security system is active, the clerk is prompted to enter the clerk passcode when they enter the Sales Registration mode. For more information on required clerk numbers, see page Setting Clerk Numbers and Names on page 28.

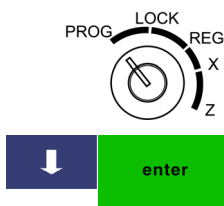

To use the clerk system

- 1 Put the REG key in the Mode key slot and turn it to the REG position.
- 2 If prompted for a passcode, use the Number keys and press the four digit passcode. Press **Enter**.

The clerk name appears in the upper left corner of the screen, above the Page Up and Page Down keys.

To use clerk numbers (example)

Example 1: Clerk #1 has a passcode of 2345

- 1 Put the REG key in the Mode key slot and turn it to the REG position.
- 2 Press 2345 and then press the **Clerk** key.

clerk

Setting X and Manager Passcodes

X and Manager passcodes are available for added security. You can set these passcodes to control access to:

- programming and Z mode (manager passcode)
- X mode.
- Additionally, you can use the Super Manager and Super Clerk passcodes that allow you to override any passcode set in the system.

Important

The Manager passcode cannot be 000000 (zeros). The cash register will not accept this passcode.

After you activate the manager or X passcodes, you must use them every time you enter programming mode or enter the X or Z report modes, depending on which you activated.

When you enter a passcode, it appears as asterisks ********* on the clerk display for extra security.

To set manager passcodes (also known as PRG/Z passcodes)

406 -- Options ▶ System Configuration Setting ▶ Passcode Setting

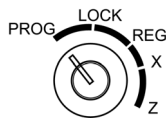

1 Put the MGR key in the Mode key slot and turn it to the PROG position.

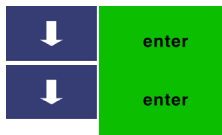

2 Press the **Arrow Down** key to select 406 -- Options. Press **Enter**.

3 Press the **Arrow Down** key to select System Configuration Setting. Press **Enter**.

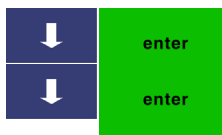

4 Press the **Arrow Down** key to select Passcode Setting. Press **Enter**.

5 Press the **Arrow Down** key to select X passcode or P&Z passcode. Press the **Enter** key

6 Follow the instructions on the screen.

To use the Super Manager Passcode

1 Put the MGR key in the Mode key slot and turn it to either the Prog or Z position.



2 At the prompt, enter 26060030 and press **Enter**.

You have access to all options available in that mode.

Caution

Only use the Super Manager passcode in “emergency” situations, such as when the manager passcode is lost.

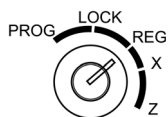

To use the Super Clerk Passcode

1 Put the MGR key in the Mode key slot and turn it to the Reg position.



2 At the prompt, enter 2606 and press **clerk**.

You are logged in as Clerk #40 and all transactions you perform are registered as Clerk #40.

Caution

Only use the Super Clerk passcode in “emergency” situations, such as when a clerk passcode is lost and a table is still open.

To use the X mode passcode after it is activated

Example 2: Go to the X mode, using the X Passcode 121212

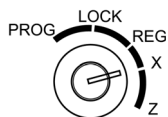

1 Put the MGR key in the Mode key slot and turn it to the X position.



2 At the prompt, enter the 6 digit X mode passcode and press **Enter**.

3 You are now ready to run and view X Reports.

To use the manager passcode after it is activated

Example 3: Go to the Z mode, using the Manager Passcode 131313

- 1 Put the MGR key in the Mode key slot and turn it to the Z position.
- 2 At the prompt, enter 131313 and press **Enter**.

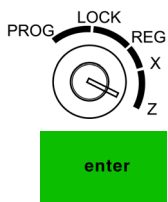

Setting the Machine Number

You can assign your cash register its own number. This is useful if you have several cash registers and want to track which one creates which receipts and transactions.

The machine number prints at the bottom of all receipts and journal records. The machine number can be up to 4 digits.

After you are done programming the machine number, you can check your results. See Printing the Program Confirmation Report on page 42.

To set the machine number

407 -- Others ▶ 424 -- Counter /No Setting

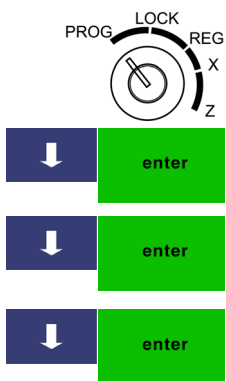

- 1 Put the MGR key in the Mode key slot and turn it to the PROG position. If prompted, enter the Manager passcode and press **Enter**.
- 2 Press the **Arrow Down** key to select 407 -- Others. Press **Enter**.
- 3 Press the **Arrow Down** key to select 424 -- Counter /No Setting. Press **Enter**.
- 4 Press the **Arrow Down** key to select Machine No Preset. Press **Enter**.
- 5 Follow the instructions on the screen.

Programming Department Keys

Departments are a category of merchandise. For example, Department 1 can be Housewares, Department 2 can be Food, Department 3 can be Hamburgers, and so on. This helps you track what you are selling.

Each department can be programmed as taxable or non-taxable, so that if an item needs to be taxed, the proper tax amount is added automatically when you ring up an item in a taxable department.

You can have as many as 200 departments on your cash register. If you have many departments, you may want to make a list so other people who use the cash register can correctly use the department keys. You can also group the departments, if you want.

When you are programming departments, remember that some departments are automatically linked to hard, or direct, department keys in Reg mode for easy usage. Departments 1 through 35 in Restaurant mode and departments 1 through 38 in Retail mode link together in this manner. The other departments are available by manually entering the department number and using the Dept key.

Programming departments includes up to 10 steps. Not all steps listed may apply to your specific needs.

- 1 Setting and programming Department names and numbers.
- 2 Setting High Digit Lock-out (HDLO)
- 3 Programming Department Preset Price
- 4 Programming Tax Status
- 5 Setting Department Groups
- 6 Setting Standard, Gallonage or Negative Mode
- 7 Setting Department Type (single or normal)
- 8 Programming Age Verification
- 9 Specify Kitchen or Backup Printer Status (not available on all versions). See Setting the KP on page 37.

For specific information about each of the items above, see the next sections.

After you are done, you can check your results. See Running the Department Confirmation Report on page 82.

To program department keys

401 -- Department Settings

- 1 Put the MGR key in the Mode key slot and turn it to the PROG position. If prompted, enter the Manager passcode and press **Enter**.
- 2 Select 401 -- Department Settings. Press **Enter**.
- 3 Follow the options on the screen to program the information for your departments.

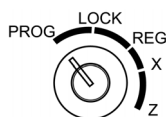

Use the **Arrow Up** and **Arrow Down** keys to highlight items on the screen.



Use the **Page Up** and **Page Down** keys to move to the next department. Press the **Enter** key to select the option to change.



The next sections explain what you can program for each department.

- 4 When you are done programming all departments, press the **Cancel** key.

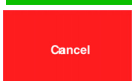

Programming Department Names and Numbers

You must assign a department number. You can specify up to 200 Department numbers.

A name or description can be assigned to each department. This name appears on the clerk screen and prints when ringing up sales. For example, Clothing can print on the receipt in place of Dept 1, Shoes can print on the receipt in place of Dept 2, Sportswear can print on the receipt in place of Department 3, and so on.

You can also specify the name that appears on the screen if you are using the hard, or direct, department keys.

When you are programming the alpha descriptions for Departments and PLUs, use the Alpha screen.

Note

Only capital letters of the alphabet initially appear on the screen. To use lower case letters, press the **caps lock** key.

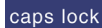

Use the Number keys to enter any numbers you want.

You may need certain special symbols. For example, if you need the / symbol, or if you need a comma, press the **Symbol** key. There are 2 pages of available symbols. For specific information about the available symbols, see Setting Alphanumeric Descriptions on page 23.



Important

If you enter the wrong character, press the **back space** key to delete the character. Now you can continue.



When you are done programming the department description, press the **Cancel** key to save your programming. The information is saved in the cash register and you can program the next item.



Setting High Digit Lock-out (HDLO)

You can specify the largest amount that can be rung up in a department entry. This feature helps to prevent against large over-rings. If too many digits are entered, the error beep sounds and you are prompted with an error message. The default HDLO is 8 digits (999999.99).



Select the HDLO limit you want and press the **Cancel** key.

Programming Department Preset Price

Department Preset Price programs a preset price in a department to save time when ringing up an entry. Even if a price has been pre-programmed, you can override the price at the time of sale.

The price automatically rings up each time that department key is pressed.

Programming Tax Status

You must collect tax on some items by law. You can program your cash register to automatically assign the right amount of tax, based on the department the item is assigned to.

You can set no tax, or link to a single tax rate (Tax 1, Tax 2, Tax 3, or Tax 4) or multiple tax rates to a department key. For information about setting the tax rates, see *Selecting the Tax System* on page 72. You must program non-tax or a tax rate for the department programming to be accepted. The default setting is non-tax for departments.

Setting the Group

You can assign departments to one of 10 groups. Assigning groups lets you run report totals for the entire group. For example, you can have a group for beverages that includes the departments for Milk, Soda, Juices, and Coffee. You can run a group report to see the sales for these beverages.

For more information about reports and groups, see *Running Management Reports* on page 83.

Setting Standard, Gallonage or Negative Mode

A department can be set for Standard Mode, Gallonage Mode, or Negative Mode.

Gallonage Mode allows entering a price with 3 decimal places, representing the cost per gallon, pound, kilogram, yard, meter, or other unit of measurement. For example, \$2.899 per gallon.

The quantity, representing the unit of measurement, can also be entered in up to 3 decimal places. This lets you enter 10.931 gallons of gasoline at \$2.899 a gallon.

Standard Mode enters the price using the normal 2 decimal place setting.

Negative Mode allows you to set the price to a negative number. This is useful when you need to assign preset discounts or coupons. Using

Negative Mode allows you to track the number of discounts given or the number of times the discounts were given more closely than simply assigning a discount amount with the **Coupon** key.

Setting Department Type

Department type can be either normal or single.

Normal item entry allows you to ring up several items before closing the transaction with method of payment (cash, check, charge, credit, and so on).

Single item setting for a department automatically ends the sale as a cash sale when you press the department key. You can still add multiple quantities, for example 5 x/time \$1.00 on a department programmed for single item sale, but the transaction ends automatically as a cash sale. This setting is useful for cash-only transactions that should not be combined with other sale items, such as lottery ticket sales.

Setting Age Limits

When you are setting up departments, you can specify that the cash register prompts the clerk to validate an age requirement before the item is rung up in that department. This helps meet legal requirements if you are selling items that are restricted to age groups, such as alcohol or tobacco.

This reminds the clerk to check ID and prompts the clerk with the appropriate age needed. This feature does not prevent sales to age inappropriate customers; it simply provides a reminder to the clerk that this is an age-controlled item.

You have 3 default options:

- No age No age validation (the default setting for each department.)
- Age 1 Prompts the clerk with a date 18 years ago from date of sale.
- Age 2 Prompts the clerk with a date 21 years ago from date of sale.

You can change the exact ages for Age 1 and Age 2.

To change the default ages for Age 1 and Age 2

407 -- Others ▶ Age Limit Setting

- 1 Put the MGR key in the Mode key slot and turn it to the PROG position. If prompted, enter the Manager passcode and press **Enter**.
- 2 Press the **Arrow Down** key to select 407 -- Others. Press **Enter**.
- 3 Press the **Arrow Down** key to select Age Limit Settings. Press **Enter**.

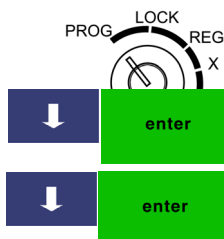

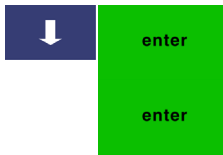

- 4 Press the **Arrow Down** key to select either Age 1 Setup or Age 2 Setup. Press **Enter**.
- 5 Using the Number keys, enter the age you want. Press **Enter**.

Setting the KP

You can specify that a department automatically prints on a back up or kitchen printer, if you are using one.

This is useful for orders that need to be prepared by kitchen/bar staff or if stock needs to be pulled from separate areas.

Important

Not all versions of the cash register support a back up or kitchen printer. Contact Royal at 1-800-243-4002 with any questions.

Programming the Credit Key

You can use up to 2 keys for credit card sales: **credit** and **charge**. You can change the name of the key labeled **credit** to show the name of the specific name, such as Visa®, for that key. The name of the credit card appears on the receipt, management reports, and electronic journal records.

When you ring up a sale, you can use credit card key to finalize the credit card sale, open the cash drawer, and print the receipt.

To program a credit key description

407 -- Others ▶ 419 -- [Credit] name

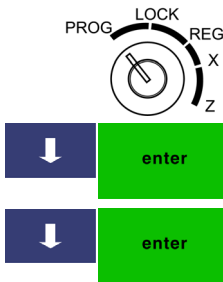

- 1 Put the MGR key in the Mode key slot and turn it to the PROG position. If prompted, enter the Manager passcode and press **Enter**.
- 2 Press the **Arrow Down** key to select 407 -- Others. Press **Enter**.
- 3 Press the **Arrow Down** key to select 419 -- [Credit] name. Press **Enter**.
- 4 Follow the instructions on the screen.

Important

If you enter the wrong character, press the **back space** key to delete the character. Now you can continue.



- 5 When you are done, press **Enter**.

Programming PLU Descriptions

The Price-Look Up system allows for fast, accurate entry of an item and automatically records the number of items sold. If you want to use the optional barcode reader, you can scan UPC codes to ring up items.

To scan barcodes, they must be numeric only, 14 digits or less, and must be one of the following barcode types and standards:

- UPC-A
- UPC-E
- EAN-8
- EAN-13

Note

This cash register cannot generate barcodes for you. To generate and print barcodes, purchase barcode software.

Each PLU must be programmed with up to a 12 character description that appears on the display and prints on the tape. You can have up to 3000 PLU items programmed. Each PLU is linked to a specific department and has the characteristics of that department.

Programming PLUs consists of the following:

- 1 Programming departments you want to use.
- 2 Assign a PLU number (from 1 to a maximum of 13 digits long) to each sales item or scan the barcode.
- 3 Enter a name description for the PLU. You must enter a description, even if it is as simple as PLU4.
- 4 Assign a price. You can specify up to 3 prices, if you want to use the Happy Hour prices that allows you to specify different prices depending on the time of day.

For example, in Retail mode, you can specify that certain books are a different price from 6 P.M. to 8 P.M. If you are using Restaurant mode, you can specify that certain entrees are a different price during lunch time.

For more information about Happy Hour pricing, see Happy Hour Settings on page 46.

- 5 Link the PLU to a department key with the appropriate Tax Status for that PLU.

For example, if PLU #1 is a taxable item, you can link it to a Department key which is set up for tax. If PLU #2 is not a taxable item, you can link it to a Department key which is programmed for no tax.

- 6 Optionally, if the inventory function is active, set or edit the inventory on-hand count. Returned merchandise affects inventory levels. For more

information about setting inventory, see System Options Settings on page 53.

- 7 Optionally, if the inventory function is active, set or edit the inventory safety margin count.
- 8 Optionally, map PLUs to direct PLU keys. See Mapping PLUs to Direct PLU Keys on page 40.

The rest of this section explains the above steps.

Important

Do not press the **Decimal point** key when entering a price.

After you are done, you can check your results. See Running the PLU Confirmation Report on page 82.

Programming PLUs without a Barcode Reader

You can program PLUs without using a barcode reader. Use the following instructions.

Important

When programming PLU alpha descriptions, if you enter the wrong character, press the **back space** key to delete the character. Now you can continue.



To program PLUs without a barcode reader

402 -- PLU Setting

- 1 Put the MGR key in the Mode key slot and turn it to the PROG position. If prompted, enter the Manager passcode and press **Enter**.
- 2 Press the **Arrow Down** key to select 402 -- PLU Setting. Press **Enter**.
- 3 Press the **Arrow Down** key to select Add New PLU or Edit PLU. Press **Enter**.
- 4 Using the Number keys, enter the PLU number. Press **Enter**.
- 5 Follow the instructions on the display
- 6 To program the next PLU, go to Next Item and press **Enter**.

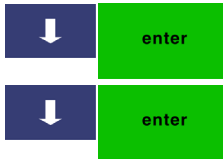
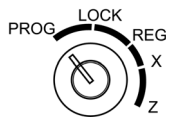

Programming PLUs with the Optional Barcode Reader

You can use the optional Royal model PS700 barcode reader to scan items and automatically ring them up. Using the barcode reader saves time and reduces errors caused by people ringing up items incorrectly. The barcode reader must be held about 1/2 inch or closer above the symbol on the product to read the UPC or other barcode properly.

back space

Important

When programming PLU alpha descriptions, if you enter the wrong character, press the **back space** key to delete the character. Now you can continue.

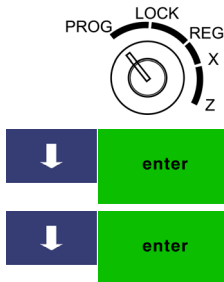

To program PLUs using the barcode reader

402 -- PLU Setting

- 1 Put the MGR key in the Mode key slot and turn it to the PROG position. If prompted, enter the Manager passcode and press **Enter**.
- 2 Press the **Arrow Down** key to select 402 -- PLU Setting. Press **Enter**.
- 3 Press the **Arrow Down** key to select Add New PLU or Edit PLU. Press **Enter**.
- 4 Using the barcode reader, scan the barcode you want for this PLU. Hold the barcode reader less than 1/2 inch from the barcode you want to scan. Press the key on the bottom of the reader. Flick the reader slightly to move the LED light along the barcode to read it. The barcode reader beeps when it properly reads the barcode.
- 5 Follow the instructions on the display to complete programming.
- 6 To program the next PLU, go to Next Item and press **Enter**.

Mapping PLUs to Direct PLU Keys

You can specify up to 240 hard, or direct, PLUs to be mapped to specific keys that show on the screen when a sale is rung up. Direct PLU setting simplifies using the cash register because during a sale, the key on the screen is touched instead of a department and a price. As a result, sales are more accurate and errors are reduced.

hard plu

After you map the direct PLUs, use them during a sale by pressing the **hard plu** key. The direct PLUs appear on the screen.

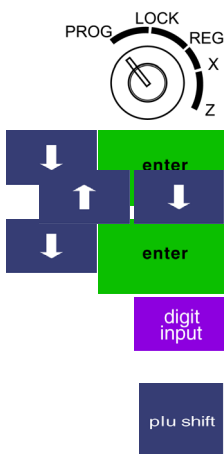

To map PLUs to hard, or direct, PLU keys

407 -- Others ▶ 411 -- Direct PLU Setting

- 1 Put the MGR key in the Mode key slot and turn it to the PROG position. If prompted, enter the Manager passcode and press **Enter**.
- 2 Press the **Arrow Down** key to select 407 -- Others. Press **Enter**.
- 3 Press the **Arrow Down** key to select 411 -- Direct PLU Setting. Press **Enter**. The PLUs you created appear on the left of the screen.
- 4 Press the **Arrow Up** or **Arrow Down** key to select the PLU you want to map.

If you know the PLU number you want to map, you can also manually enter the number or scan the barcode with the barcode reader. Press the **digit input** button to use this feature.

- 5 Press the Direct PLU key on the screen that you want to use for that PLU. To see more available direct keys, press **plu shift**.
- 6 Repeat until all the PLUs you want to map are done. To clear an assigned key, press **void** and the key you want to delete.
- 7 When you are done, press the **cancel** key.



Editing a PLU

After you create a PLU, you may want to edit it. Use the following instructions.

To edit a PLU

402 -- PLU Setting

- 1 Put the MGR key in the Mode key slot and turn it to the PROG position. If prompted, enter the Manager passcode and press **Enter**.
- 2 Press the **Arrow Down** key to select 402 -- PLU Setting. Press **Enter**.
- 3 Press the **Arrow Down** key to select Add New PLU or Edit PLU. Press **Enter**.
- 4 Do one of the following:
 - Using the Number keys, enter the PLU number you want to edit and press **Enter**.
 - Using the barcode reader, scan the barcode you want edit.
- 5 Make your changes to the PLU information. Use the **Arrow Up** key and **Arrow Down** key to move through the selections.
- 6 To edit the next PLU, go to Next Item and press **Enter**.
- 7 When you are done, press the **cancel** key.

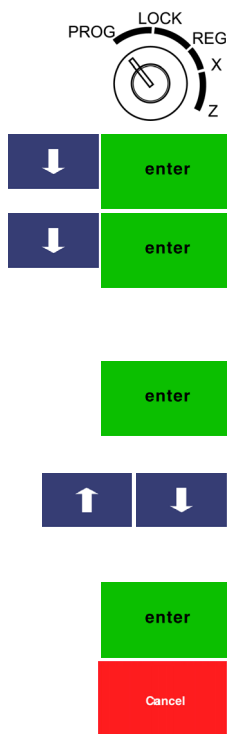

Deleting a PLU

You can delete a PLU if you no longer want to use it. Before you delete a PLU, make sure you select the correct PLU to delete. After you delete a PLU, you cannot change it.

Before you delete a PLU, you must clear the PLU Z reports. For more information about clearing Z reports, see About Z Reports on page 85.

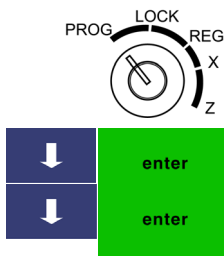

To delete a PLU

402 -- PLU Setting

- 1 Put the MGR key in the Mode key slot and turn it to the PROG position. If prompted, enter the Manager passcode and press **Enter**.
- 2 Press the **Arrow Down** key to select PLU Setting. Press **Enter**.
- 3 Press the **Arrow Down** key to select Delete a PLU. Press **Enter**.
- 4 Do one of the following:
 - Using the Number keys, enter the PLU number you want to delete and press **Enter**.
 - Using the barcode reader, scan the barcode you want delete.
- 5 At the prompt, press the **Yes** key.

Printing the Program Confirmation Report

Now that basic programming is complete, check your results with a Program Confirmation Report.

If you made a mistake during programming, repeat only the step you made the mistake in. For example, if only the tax rate is incorrect, just re-program the tax—you do not need to re-set the time, date, and so on.

There are 4 types of confirmation reports:

- Dept All the department programming. See Running the Department Confirmation Report on page 82.
- PLUs All PLU programming. See Running the PLU Confirmation Report on page 82.
- Clerks All clerks. See Running the Clerk Confirmation Report on page 82.
- Options All the parameters for setting the register, including header, footer, tax rates and so on. See Running the Options Dump Report on page 43.

Before Going to Register Mode

Your cash register offers many other features not covered in this chapter. If you are using the cash register in Restaurant mode, there are several options covered in Setting Up Your Cash Register for Restaurant Mode on page 44.

Other options are covered in the chapter called Navigating Your Cash Register Parameters, starting on page 47. We also provide examples to

help you learn how to use your cash register. For information about the examples, see Examples on page 101.

Running the Options Dump Report

When you are done programming the cash register, you can print the settings to verify your selections.

For specifics about running the Options Dump Report, see Options Dump Report on page 56.

Clearing Errors

If you make a mistake, the cash register prompts you with an error message. Press the **Return** key to go back and correct your mistake.

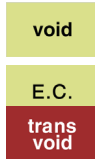

To erase an entry after you press a key that printed the entry on the tape during a sales transaction, use the **Void** or the **EC** keys to undo the entry.

To void an entire incorrect transaction, press the **trans void** key.

If your cash register does not stop making a beeping sound after you press the **Return** key, you can do one of two actions:

Turn the cash register off

Turning the cash register off can help. For more information, see Performing a Partial Reset on page 98.

Master Reset

As a last resort, you can do a Master Reset. For more information about the Master Reset, see Performing a Master Reset on page 98.

Note

A Master Rest deletes all settings.

Setting Up Your Cash Register for Restaurant Mode

If you decide to operate in Restaurant mode, certain options are available. This chapter includes explanations for:

- Setting restaurant mode
- Setting cooking messages
- and more

When you are ringing up sales, the current mode appears in the upper left area of the header.

Using the restaurant-specific table features is explained in Using Tables on page 65.

Setting Restaurant Mode

The cash register is set to restaurant mode by default. You can manually change this mode at any time.

Caution

Resetting the cash register to restaurant mode deletes all transaction and programming information. Make sure you print or save any information you want to keep before you continue.

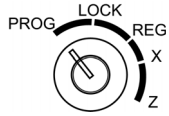

To set the cash register to restaurant mode

406 -- Options ▶ System Configuration Setting

- 1 Put the MGR key in the Mode key slot and turn it to the PROG position. If prompted, enter the Manager passcode and press **Enter**.
- 2 Press the **Arrow Down** key to select 406 -- Options. Press **Enter**.
- 3 Press the **Arrow Down** key to select System Configuration Setting. Press **Enter**.
- 4 Press the **Arrow Down** key to select Working Mode. Press **Enter**.
- 5 Select Restaurant. If you see a warning prompt, press Yes.



Setting Cooking Messages

When food or drink is ordered, sometimes you need to give instructions with the order. For example, if you offer steak, the wait staff can specify the steak to be cooked Medium.

You can have up to 48 cooking messages. Each message can be up to 24 characters long.



The wait person can select a message when they ring up items by pressing the **C.M.** key. For more information, see *Using Cooking Messages* on page 67.

After a transaction round with a cooking message is completed, a *Send Successful* message appears if the communication with the backup printer worked.

Note

The cooking message feature is not available on all versions. Contact Royal for more information.

To program cooking messages

407 -- Others ▶ 419 -- Cooking Message Set

- 1 Put the MGR key in the Mode key slot and turn it to the PROG position. If prompted, enter the Manager passcode and press **Enter**.
- 2 Press the **Arrow Down** key to select 407 -- Others. Press **Enter**.
- 3 Press the **Arrow Down** key to select 419 -- Cooking Message Set. Press **Enter**.
- 4 Press the **Arrow Down** key to select the message number you want to change. Press **Enter**.
- 5 Using the alphanumeric keys that appear on the screen, type your message. When you are done, press **Enter**.
- 6 Repeat to add more messages.

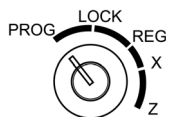

Happy Hour Settings

Happy hours prices are only available if you use PLUs. For each PLU, you can program a standard price and two additional price levels that are valid at specific times of day.

Happy hour prices are useful if you have specials on food or drink at certain times of the day. You can also use this for different prices on the same items on a lunch menu and a dinner menu.

The time format for happy hour settings defaults to the format the cash register clock is set to. For example, if you have the cash register clock set to use AM and PM, then the happy hours times you see are shown as AM and PM. The prices appear on the header during the time of day they are set for.

Before you start, you must have PLUs set up. For more information about setting up PLUs, see Programming PLU Descriptions on page 38.

To set the times for Happy Hour

407 -- Others ▶ 420 -- Happy Hour Setting

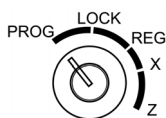

- 1 Put the MGR key in the Mode key slot and turn it to the **PROG** position. If prompted, enter the Manager passcode and press **Enter**.
- 2 Press the **Arrow Down** key to select 407 -- Others. Press **Enter**.
- 3 Press the **Arrow Down** key to select 420 -- Happy Hour Setting. Press **Enter**.
- 4 Press the **Arrow Down** key to select the first setting time you want to change. Press **Enter**.
- 5 Follow the instructions on the screen for setting each time.

Restaurant Reports

In restaurant mode, you have several restaurant-specific report options available to you.

X mode

- Table Report
- Active Table Report

Z mode

- Table Report

For specific information about running reports, see Running Reports on page 81

Navigating Your Cash Register Parameters

This chapter shows you more advanced programming for your cash register. This chapter is organized to show you the menu options shown in the clerk display. Use this chapter to quickly find a menu option you want.

Some of the menu options in this chapter are already discussed elsewhere in this manual. In those cases, we provide references where you can see more detailed information.

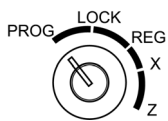

To see the programming options, put the MGR key in the Mode key slot and turn it to the PROG position. If prompted, enter the Manager passcode and press **Enter**.

401 Department Settings

Specifies department settings. For detailed information about programming departments, see Programming Department Keys on page 32.

Also allows you to Print All Programmed Departments.

402 PLU Settings

These PLU options are available.

Table 3 PLU setting options

Option	Description
Add New PLU or Edit PLU	Specifies new PLUs or edits existing PLUs. For more information, see Programming PLU Descriptions on page 38.
Delete a PLU	Deletes an existing PLU.
Print PLU Parameters	Print a report showing all programmed PLUs and their settings.

403 Clerk Settings

Specifies clerk names, numbers, and passcodes to use with the clerk system. For more information, see Using the Clerk System on page 30.

Also allows you to Print Programmed Clerks.

404 Tax Settings

Specifies direct programming for Taxes 1 through 4 and lets you specify the tax limits. For detailed information about programming tax, see Programming Tax Status on page 35.

405 Text Settings

Specifies the text for receipt messages. These options are available.

Table 4 Text setting options

Option	Description
Header Message	Specifies the header messages on the receipt.
Footer Message	Specifies the footer messages on the receipt.
Set to Default	Resets the text options to the factory default.

For detailed information about receipt messages, see [Printing Options on Receipts](#) on page 28.

406 Options

Printing Parameters Settings

The Print Parameters menu includes the options listed in this section.

To open the Print Options menu

406 -- Options ▶ Printing Parameter Settings

- 1 Put the MGR key in the Mode key slot and turn it to the PROG position. If prompted, enter the Manager passcode and press **Enter**.
- 2 Press the **Arrow Down** key to select 406 -- Options. Press **Enter**.
- 3 Press the **Arrow Down** key to select Print Parameters Settings. Press **Enter**.

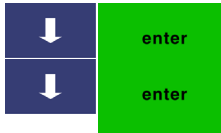
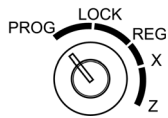

These options are available.

Table 5 Printing parameters options

Option	Description
Print Date on Receipt	Specifies if the Date prints on the customer receipt.
Print Time on Receipt	Specifies if the Time prints on the customer receipt.
Print Clerk on Receipt	Specifies if a Clerk name prints on the customer receipt. For information about setting clerk names, see Using the Clerk System on page 30.
Print Header on Receipt	Specifies if the Header prints on the customer receipt. For more information about header messages, see Setting Header Messages and Footer Messages on page 25.
Print Footer on Receipt	Specifies if the Footer prints on the customer receipt. For more information about footer messages, see Setting Header Messages and Footer Messages on page 25.

Table 5 Printing parameters options (continued)

Option	Description
Print Tax Amount on Receipt	<p>Specifies if each individual tax rate amount (Tax-1, Tax-2, Tax-3 and Tax-4) prints on the receipt as separate amounts.</p> <p>For more information about tax rates, see Programming Tax Status on page 35 and Programming Complex Tax Rates on page 71.</p>
Print Tax Total	Specifies if the total of all applicable tax rates is printed on the receipt.
Print Blank Line	<p>Specifies if blank lines are printed in the Header and Footer or whether blank lines are skipped.</p> <p>For example, if you only wanted a 2-line header, you can program the first two lines and then make the remaining 3-lines blank.</p> <p>Then you can either set this option to print those blank lines for extra spacing or to skip those 3 blank lines to save on paper.</p>
Print SUB Amount	Specifies to automatically print the Sub-Total on all receipts.
Print SUB when Subttl pressed	Specifies if the subtotal prints when the Subtotal key is pressed during a transaction.
Print Machine # on Receipt	Specifies if the Machine number is printed on the receipt. For more information about setting machine numbers, see Setting the Machine Number on page 32.
Print Receipt# on Receipt	Specifies if the Consecutive Transaction number is printed on the sales receipt and on the X and Z reports.
Zero Item Skip for Report	Specifies if items in the report with no sales information should print. Setting this option to Yes can save a lot of paper when you print reports.

Table 5 Printing parameters options (*continued*)

Option	Description
Print the Zero Inventory	Specifies to print items or not print items with zero inventory when printing a PLU inventory report.
Duplicate Receipts Allowed	<p>Specifies if duplicate receipts are allowed. You may not want to allow issuing a second receipt for security reasons. Issuing a second receipt can be useful for rebates, or to reprint the receipt in case the printer runs out of paper or jams in the middle of a sale.</p> <p>Caution This option affects reprinting a single copy of the receipt if the receipt printer was turned off or if operating in receipt-on-demand mode. Make sure this option is set to On if the printer will be turned off.</p>
Print the Z Counter	Specifies if a Z report counter prints when printing a Z report.
Print Department # When PLU sale	<p>Specifies if just the PLU name/description is printed on the receipt on one line; or both, the PLU name/description and the PLU number (or the UPC bar code number, if it was a bar code) are printed on the receipt over 2 lines. Because the receipt paper is not wide enough to print both pieces of information on one line, it is split over 2 lines. Each PLU prints on 2 lines of the receipt with the second option.</p> <p>The PLU number and name option is more descriptive and helps in a retail setting when a customer might return a product or where there are warranty claims.</p> <p>The Name Only option saves on receipt paper and is fine for simpler settings, such as a pizza parlor, restaurants and other smaller retail where you do not have returns or warranty claims on products.</p>
Print #/NS information	Specifies if a no sale receipt prints.

Table 5 Printing parameters options (*continued*)

Option	Description
Receipt On or Off	Specifies to print or not to print a receipt.
Print Local Currency Symbol	Specifies if the local currency symbol prints on the receipt.
Print Barcode when PLU sale	Specifies if the barcode for a PLU item prints on the receipt.
Picture Logo Print	Specifies to print the logo on the receipt.
Position of Logo Print	Specifies the location of the logo, if printed. For more information, see Printing Picture Logos on Receipts on page 27.

System Options Settings

The System Options menu includes the options listed in this section.

To open the System Options menu

406 -- Options ▶ System Options Setting

- 1 Put the MGR key in the Mode key slot and turn it to the PROG position. If prompted, enter the Manager passcode and press **Enter**.
- 2 Press the **Arrow Down** key to select 406 -- Options. Press **Enter**.
- 3 Press the **Arrow Down** key to select System Options Setting. Press **Enter**.

These options are available.

Table 6 System options settings

Option	Description
Inventory Function Active	Specifies if you want to use the inventory function to track the number of items sold and the remaining items on hand when using PLUs. For more information, see Programming PLU Descriptions on page 38.
Safety Inventory	Specifies the low inventory level at which you want to be notified. This helps you know when you may be running low on an item and need to reorder.
Zero Price for Department PLU Sale	Specifies if zero price entry for PLUs and Departments is allowed.
EJ Features Active	Turns the Electronic Journal on or off.
	The Electronic Journal can hold 10,000-lines of transactions in memory. When it is turned on, the Electronic Journal records in the internal memory the line-by-line details of all the transactions and items completed on the cash register and printed on the printer. All sales transactions and using the #/NS key to open the cash drawer are recorded.
Compulsory Declaration	Specifies if the clerk must always enter the amount of money the customer gives the clerk so the clerk sees the amount of change to give back to the customer. This can reduce cash drawer shortages. This setting applies to all forms of payment.

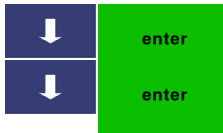
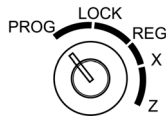

Table 6 System options settings (continued)

Option	Description
Reset Receipt # after Z Rep	Specifies to reset the Consecutive Transaction number found on each sales receipt and on most reports after running each Z report.
Reset Z Counter after Z Rep	Specifies to reset the Z counter number after running each Z report.
Reset Grand Total after Z Rep	Specifies to reset the Grand Total Amount on the Z-report after running each Z-report.
Clerk System Active	Specifies to use the Clerk system.
Currency Symbol Choice	Specifies the Currency Symbol for the register for the Local Currency. This is the symbol for the main currency of the register and not the foreign currency. You can only select from the list of symbols offered.
Beep when Key is Pressed	Specify if the keys beep when pressed on the touch screen.
Pass Code active in X Mode	Specifies if a passcode should be entered to access X mode reports.
Pass Code active in P&Z Mode	Specifies if a passcode should be entered to access Z mode reports and Programming Mode.
Compulsory Clerk Declaration	Specifies if the clerk passcode must be entered before every sale.
Z Report 2nd Copy Active	<p>Specifies to allow reprinting a second copy of the Z report. If you set this option to “single”, then you cannot recover or print another copy of the Z-Report after it is generated.</p> <p>If the printer runs out of paper or jams, there is no way to re-print the Z-report or to recover that information. Allowing a second copy lets you install a new roll of paper or correct a jam or some other problem and then reprint the same Z-report one time for a second copy. Additional copies are not allowed.</p>

System Configuration Settings

These options are available.

Table 7 System configuration settings

Option	Description										
Date Format	Select from MM-DD-YY or DD-MM-YY.										
Date Adjust	Specify the date, including month, date, year.										
Time Format	Specify 12-Hour format with AM and PM designations or 24-hour format (Military time).										
Time Adjust	Adjust the time: hours and minutes.										
Language	Specify the default language of the machine for all the prompts, messages, on-screen instructions, and so on. Important Not all versions of the cash register support multiple languages.										
Tax System	Select the Tax System <ul style="list-style-type: none"> • Add-on (USA) • Canadian • VAT (Value-Add Tax). See Programming Complex Tax Rates on page 71 for detailed explanation of the Tax Systems and setting taxes.										
Decimal Select	The decimal point is set by selecting from the following 4 options: <table border="1" data-bbox="760 1465 1430 1789"> <thead> <tr> <th>This decimal point...</th> <th>Looks like...</th> </tr> </thead> <tbody> <tr> <td>zero decimal point</td> <td>0 = \$ X</td> </tr> <tr> <td>one decimal point</td> <td>1 = \$ X.X</td> </tr> <tr> <td>two decimal point</td> <td>2 = \$ X.XX (U.S. Standard)</td> </tr> <tr> <td>three decimal point</td> <td>3 = \$ X.XXX</td> </tr> </tbody> </table>	This decimal point...	Looks like...	zero decimal point	0 = \$ X	one decimal point	1 = \$ X.X	two decimal point	2 = \$ X.XX (U.S. Standard)	three decimal point	3 = \$ X.XXX
This decimal point...	Looks like...										
zero decimal point	0 = \$ X										
one decimal point	1 = \$ X.X										
two decimal point	2 = \$ X.XX (U.S. Standard)										
three decimal point	3 = \$ X.XXX										

Table 7 System configuration settings (continued)

Option	Description
	<p>After you program the decimal point, you do not need to press the Decimal key when you ring up sales or during programming. If you use a decimal point when you enter a price, you hear an error beep and see an error message.</p> <p>The only time you use the decimal point key is when you are ringing up the quantity of a sale. For example, 10.25 gallons of gasoline or 1.875 pounds of deli meat.</p> <p>After you are done, you can check your results. See <i>Running the Options Dump Report</i> on page 43.</p>
Working Mode	Specifies Restaurant or Retail mode. After you select a mode, if you change modes, you lose all programming.
Pass Code Setting	Select the passcodes you want to change.
Power Saving	<p>Select the amount of time before the touch screen turns-off and goes-to-sleep into Power Saving mode. The cash register only “goes to sleep” after the specified number of minutes of no activity. It does not go to sleep in the middle of a sales transaction.</p> <p>For more information, see <i>Using Power Saving Mode</i> on page 17.</p>

Return to Machine to Default Settings

Returns all the Options to factory default settings. It is strongly recommended that you run a Z-report and any other reports first, because resetting to default settings affects these reports. After running the Z-report, return to this option and continue with resetting to factory default settings.

Options Dump Report

This report contains all the parameter option settings for the cash register and in the following order:

- Print Options
- System Options
- Header text
- Footer text
- Other options programming
- Tax System

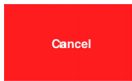

This report can use a lot of paper. Before you print, make sure you have enough paper installed in the receipt printer. You can stop printing by pressing the **cancel** key.

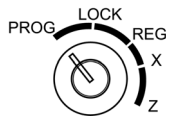

To print the Options Dump Report

406 -- Options ▶ Option Dump

- 1 Put the MGR key in the Mode key slot and turn it to the PROG position. If prompted, enter the Manager passcode and press **Enter**.
- 2 Press the **Arrow Down** key to select 406 -- Options. Press **Enter**.
- 3 Press the **Arrow Down** key to select Option Dump. Press **Enter**.

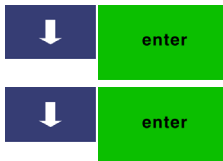

407 Others

411 Direct PLU Setting

Specifies to link a previously programmed PLU to a specific key. When the clerk presses the key, the item is automatically rung up. For more information, see Mapping PLUs to Direct PLU Keys on page 40.

412 Coupon Setting

Specifies the preset price and the tax/HDLO settings for a coupon. You can over-ride this preset price at any time during a transaction.

413 Discount Setting

Specifies up to 3 percentage amounts. Specify a name and a percentage to reduce the price of the item or a percentage to increase the price of the item. This amount can be overridden at any time during a transaction.

414 HDLO Setting

Specifies setting a HDLO (High Digit Lock-Out) Limit. For more information, see Setting High Digit Lock-out (HDLO) on page 34.

415 Cash in Drawer Limit

Specifies the total amount of cash allowed in the drawer. When that amount of cash is rung up and in the drawer, the clerk sees a message to remind them that there is too much cash in the drawer.

416 FC Setup

You can specify a foreign currency to be accepted as payment. You program the exchange rate versus the local currency.

This is useful if you are working in a multiple currency situation and want to accept another currency, such as stores near a border with another country. When you are ready to complete the sale, you can press the **FC** key, select the currency, and see the total sale in the foreign currency. Enter the amount of foreign currency the customer gives you and press **Enter**.

Note

You can program four foreign currencies.

Follow the instructions on the screen, providing the following information.

- **FC Name** The name of the foreign currency. For example, Pesos.
- **Local** Your local currency unit to exchange against. For example, \$1.00.
- **FC Rate** The amount of the foreign currency equal to the local currency amount mentioned above. For example, if US \$1.00 is equal to 8.00 pesos, then enter 8.00 in the FC Rate.
- **FC Decimal** The number of decimals in the foreign currency.
- **Currency Symbol** The currency symbol for the foreign currency.

417 Age Limit Setting

Specifies the minimum age for AGE-1 and AGE-2 of the Age Verification feature. The factory default for Age-1 is 18 years old and the factory default for Age-2 is 21 years old. For more information, see Setting Age Limits on page 36.

418 [Credit] Name

Programming the name and description for the Credit key. For more information, see Programming the Credit Key on page 37.

419 Cooking Message Set

Specifies up to 48 text cooking messages. These messages can be cooking instructions or other important information in Restaurant mode. For more information about specifying these messages, see *Setting Cooking Messages* on page 45.

Note

The cooking message feature is not available on all versions. Contact Royal for more information.

420 Happy Hour Setting

Specifies 2 more prices for PLUs and the times of day they are valid for. For more information, see *Happy Hour Settings* on page 46.

421 Picture Logo Choice

Specifies the logo to use on either the header message or the footer message. Select one of the following logos:

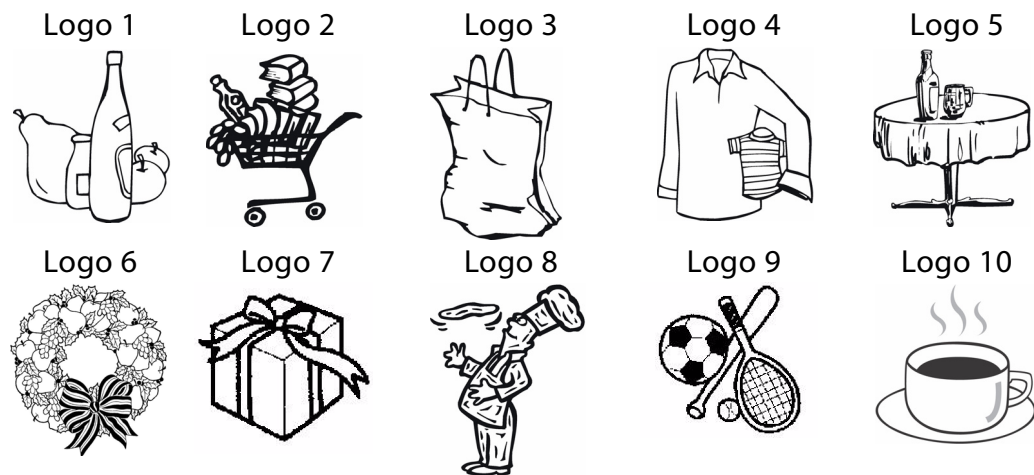

For more information, see *Printing Picture Logos on Receipts* on page 27.

422 Counter /No Setting

Specifies the preset number for the daily Z, Periodic Z, receipt number, and cash register machine number. If you have a particular number sequence you want to use for these items, you can enter them here.

For more information on setting the cash register machine number, see *Setting the Machine Number* on page 32.

423 PC Communication

Specifies the cash register is ready to communicate to an optional externally connected computer.

424 ISP Upgrade

Used to upgrade the cash register software. Only use when instructed by customer support.

425 Version Information

Shows the version information for the software in the cash register.

426 System Information

Shows the number of Dept, PLU, and clerks programmed versus the number allowed in the cash register. Also shows the Electronic Journal status in number for available lines.

For more information, see [More Information about the Electronic Journal \(EJ\) Reports](#) on page 88.

Ringling up Sales and Using Training Mode

After you set up your cash register, ringing up sales is easy. For information about ringing up complicated sales, see Examples on page 101.

If you want to learn to use the cash register without affecting the daily total, you can use the Training mode. You or someone else can learn how to use the cash register without creating real sales that show up on reports. For example, you can train a new person about using the department keys, PLUs, and completing sales.

When you exit from the Training mode, the training sales information is deleted.

To use Training mode, you need to have a training passcode set. For more information, see Setting the Training Passcode on page 69.

Price and tax calculations use the 5 up and 4 down rounding method. For all calculations creating a value with a longer decimal length than what the current active setting is, the number is rounded accordingly to conform with the setting. Values ending with 5 or more are rounded up and values ending with 4 or less are rounded down.

For example: If 5 gallons of gas are sold at a price of \$2.669 per gallon, the actual cost is \$13.345. Because fractions of cents are not used, this is rounded up to \$13.35.

Ring up Sales

After you have the basics programmed in your cash register, you are ready to ring up sales. For more information about setting up the basics on your cash register, see *Setting Up Your Cash Register - the Basics* on page 21.

Reminder

Do not press the **Decimal Point** key when ringing up a price.

Ring up Sales without a PLU Number

You can ring up a sale for an item that does not have a PLU number. You must select a department if you are ringing up an item this way.



To ring up a straight cash sale without a PLU number

- 1 Put the REG key in the Mode key slot and turn it to the Reg position.
- 2 If the clerk numbers are set, press the four digit passcode and then press the **Clerk** key.
- 3 Using the Number keys, enter the price of the first item.
- 4 Press the **Department** key for that item.

In Restaurant mode, to use the Department keys from 6 to 35, do the following:



- Press the **Dept Shift** key and press the department number you want to use.

In Retail mode, to use department numbers from 9 to 38, do the following:



- Press the **Dept Shift** key and press the department number you want to use.

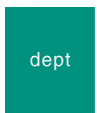

You can also manually enter the Department number in either mode by entering the Department number and then pressing the **Dept** key.



- 5 Repeat for the rest of the items.
- 6 When you are done ringing up items, press **subtotal** to see the transaction detail.
- 7 Press the **Amount Tender** key to complete the sale. The cash drawer opens and the receipt prints.
- 8 Make any change needed and place the money you are given in the cash drawer. Close the cash drawer.
- 9 Give the customer the receipt, if the cash register is set to print receipts.
- 10 You are ready to ring up another sale.

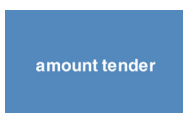
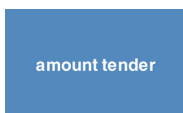

Ringing up Sales with a PLU Number

You can ring up a sale for an item that has a PLU number programmed.



To ring up a straight cash sale with a PLU number and not using the barcode reader

- 1 Put the REG key in the Mode key slot and turn it to the Reg position.
- 2 If the clerk numbers are set, press the four digit passcode and then press the **Clerk** key.
- 3 Using the Number keys, enter the PLU number of the first item.
- 4 Press the **PLU** key.
Repeat for the rest of the items.
- 5 When you are done ringing up items, press the **Amount Tender** key. The cash drawer opens and the receipt prints.
- 6 Make any change needed and place the money you are given in the cash drawer.
- 7 Close the cash drawer.
- 8 Give the customer the receipt, if the cash register is set to print receipts. You are ready to ring up another sale.

Ringing up Sales with a Direct PLU Key

You can ring up a sale for a programmed item that has a direct PLU key linked to it.

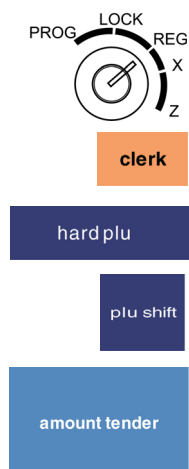

To ring up a straight cash sale with a direct PLU key

- 1 Put the REG key in the Mode key slot and turn it to the Reg position.
- 2 If the clerk numbers are set, press the four digit passcode and then press the **Clerk** key.
- 3 Press the **Hard PLU** key.
- 4 Select the PLU you want. To see more PLUs, press the **plu shift** key.
Repeat for the rest of the items.
- 5 When you are done ringing up items, press the **Amount Tender** key. The cash drawer opens and the receipt prints.
- 6 Make any change needed and place the money you are given in the cash drawer. Close the cash drawer.
- 7 Give the customer the receipt, if the cash register is set to print receipts. You are ready to ring up another sale.

Ring up Sales with the Optional Royal Barcode Reader

You can also ring up sales using the optional Royal PS 700 barcode reader. Before you can ring up sales with the barcode reader, the barcode number must be programmed into the cash register with the barcode reader. For more information, see Programming PLUs with the Optional Barcode Reader on page 39.

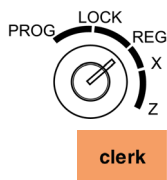

To ring up a cash sale with the barcode reader

- 1 Put the REG key in the Mode key slot and turn it to the Reg position.
- 2 If the clerk numbers are set, press the four digit passcode and then press the **Clerk** key.
- 3 Put the barcode reader light over the barcode, about 1/2 inch or closer above the UPC symbol on the product to read the barcode properly.
- 4 Press the key on the reader and flick the reader slightly to move the red LED over the barcode. The barcode reader makes a beep sound and the item appears on the display.
- 5 Continue using the barcode reader to scan bar code symbols until you are done.
- 6 When you are done, press the **Amount Tender** key. The cash drawer opens and the receipt prints.
- 7 Make any change needed and place the money you are given in the cash drawer. Close the cash drawer.
- 8 Give the customer the receipt, if you set the cash register to print receipts. You are ready to ring up another sale.

amount tender

Printing Receipts

You can turn the receipt printer on or off in Programming mode.

The receipt printer is on by default and prints the customer receipt for all transactions. All features of the cash register print as programmed. Normally, a customer receipt is printed for every transaction.

If the receipt printer is turned off, the machine will not print a customer receipt. All transaction details are still saved in the Electronic Journal memory if it is active.

If you are a smaller merchant or business, you may not need to print customer receipts. This controls the amount of receipt paper you use. In this case, you do not print a receipt for every transaction and only print a receipt for those transactions where one is required.

You must have paper installed in the printer even if you do not plan on printing receipts.

You can see the receipt printer status by looking at the upper right portion of the transaction header while in Sales registration mode. If you see the word "OFF", receipt are not set to print.

Note

You cannot change printing receipts in the middle of a transaction.

To turn printing receipts on or off

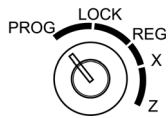

1 End the current transaction.

1 Put the MGR key in the Mode key slot and turn it to the PROG position. If prompted, enter the Manager passcode and press **Enter**.

2 Press the **Arrow Down** key to select 406 -- Options. Press **Enter**.

3 Press the **Arrow Down** key to select Printing Parameters Setting and then select Receipt On/Off.

4 Select to option you want.

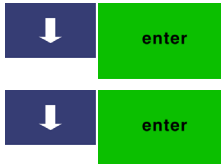

Receipt on Demand

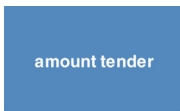

If the receipt printer is turned off, you can still print a receipt if a customer request one. After the transaction is completed, but before you start another transaction, press the **amount tender** key to print out a receipt.

Using Tables

If you are using the cash register in restaurant mode, you can use the tables features. You can use multiple tables and up to 40 server staff, as well as transferring tables, closing tables, and viewing all open tables.

You must have the Tables feature active. For more information, see Setting Working Mode on page 21.

Opening and Closing Tables

If you are using the cash register in restaurant mode, you can open and close tables. This lets the wait staff open table 12, for example, and add orders to the bill without ending the sale. When the wait person is done adding to the order, s/he can close the table to finalize later.

Important

Only the wait person that opened the table has access to it, unless it is transferred.

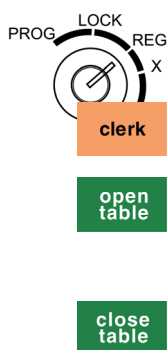

To open and close a table

- 1 Put the REG key in the Mode key slot and turn it to the Reg position.
- 2 If the clerk numbers are set, press the four digit passcode and then press the **Clerk** key.
- 3 Enter the table number you want to open. Press the **open table** key.
- 4 Add the order information you want.
- 5 When you are done, press the **close table** key.

Transferring Tables

A wait person can transfer an active table to another table. This is useful, for example, if patrons move from the bar to a table in the restaurant.

The currently logged in clerk is in control of any table transferred while they are logged in. When transferring tables, the current active clerk will be the new default clerk after any transfers take place.

For example, if Bill has tables 1 and 2 and Susan logs in and transfers table 1 to table 3, Susan becomes the assigned clerk for table 3. This also applies to the Super Clerk code used in emergency situations. For more information about the Super Clerk, see Setting X and Manager Passcodes on page 30.



To transfer a table

- 1 Put the REG key in the Mode key slot and turn it to the Reg position.
- 2 If the clerk numbers are set, press the four digit passcode and then press the **Clerk** key.
- 3 Press the **transfer table** key.
- 4 Follow the instructions on the screen. When you are done, a confirmation of the table transfer will appear on the screen and print.

Viewing Active Tables

You can view all active open tables. You can see sales totals and clerk names. If you do not have the clerk IDs set, you see N/A as the clerk name.

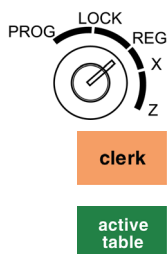

To view active tables

- 1 Put the REG key in the Mode key slot and turn it to the Reg position.
- 2 If the clerk numbers are set, press the four digit passcode and then press the **Clerk** key.
- 3 Press the **active table** key.



- Optionally, open a table by entering the table number and pressing the **open table** key.

Using Cooking Messages

If cooking messages are set, you can specify instructions for an order.

Note

The cooking message feature is not available on all versions. Contact Royal for more information.

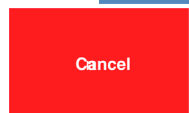
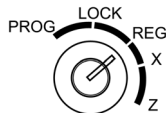
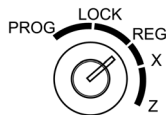

To select a cooking message during a transaction

- Put the REG key in the Mode key slot and turn it to the Reg position.
- If the clerk numbers are set, press the four digit passcode and then press the **Clerk** key.
- Open the desired table.
- Ring up an item.
- Press the **CM** key.
- Enter the number of the message you want to select. If needed, press the **Arrow Up** and **Arrow Down** keys to see more.
- When you are done, press the **CM** key.
- Complete the sale.

To manually add cooking instructions

- Put the REG key in the Mode key slot and turn it to the Reg position.
- If the clerk numbers are set, press the four digit passcode and then press the **Clerk** key.
- Open the desired table.
- Ring up an item.
- Press the **#/ns** key. The alphanumeric screen appears.
- Enter your message. When you are done, press **Enter** or press **cancel** to go back.

Printing the Bill



When a table is complete or you need to present the check, you can print the bill. Print the bill using the **bill print** key to keep the table active. Further items can be added.

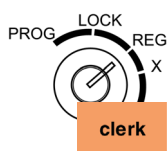

To print the bill

- 1 Put the REG key in the Mode key slot and turn it to the Reg position.
- 2 If the clerk numbers are set, press the four digit passcode and then press the **Clerk** key.
- 3 Open an existing or new table.
- 4 Do one of the following:
 - To print the bill to give to the customer, press **Bill Print** key. You can still add items to the table and you can access the table at any time.
 - To finalize the bill and close the table, enter a payment method. The table is finalized and no more items can be added.



The bill prints.

Closing Out or Ending Tables

When the customer is ready to pay and leave, the table can be closed out, or finalized, and you cannot add more items to it.

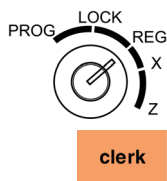

To close out, or end, a table

- 1 Put the REG key in the Mode key slot and turn it to the Reg position.
- 2 If the clerk numbers are set, press the four digit passcode and then press the **Clerk** key.
- 3 Open the active table you are ready to close out.
- 4 Enter the payment method to end the sale and print a receipt.

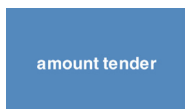

Using Training Mode

We provide examples to help learn how to use this cash register. For information about the examples, see Examples on page 101. Using the examples can help you learn to use the cash register and the available features.

You can enter the Training mode at any time in the Sales Registration mode because it does not record activity in the machine totals. However, you cannot enter Training mode in the middle of a transaction. Complete any transactions, close any tables, run all needed reports, and finalize any programming before you enter Training mode.

When you are using the cash register in Training mode, transaction numbers and amounts are not counted in the Register totals until you exit Training mode. Transactions in Training mode do not appear in any reports but they are saved in the Electronic Journal.

When the cash register is in Training mode, the word *Training* appears in the upper left of the touch screen. The word *Training* prints in the header above transaction information on the receipt.

When you stop Training mode, the transaction numbers continue from the last number printed before you entered Training mode.

Welcome! Call again!			
* Training *			
Item Name	Price	Qty	Total
PLU0300	30.30	1	30.30
PLU0600	60.60	1	60.60
PLU0900	90.90	1	90.90
SUB			181.80
CASH			181.80
Total Qty			3
Date 01-01-2004		Time	11:36
Clerk01		0001	#0055

Setting the Training Passcode

Entering training mode requires a passcode. By default, the passcode is 123456. You can change the passcode at any time.

To set the training mode passcode

406 -- Options ▶ System Configuration Setting ▶ Passcode Setting ▶ Training Mode Pass Code

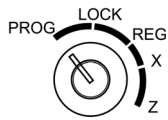

1 Put the MGR key in the Mode key slot and turn it to the PROG position. If prompted, enter the Manager passcode and press **Enter**.

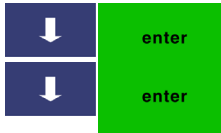

2 Press the **Arrow Down** key to select 406 -- Options. Press **Enter**.



3 Press the **Arrow Down** key to select System Configuration Settings. Press **Enter**.

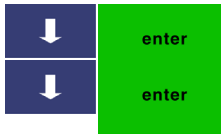

4 Press the **Arrow Down** key to select Passcode Setting. Press **Enter**.



5 Press the **Arrow Down** key to select Training Mode Pass Code. Press **Enter**.

6 Using the Number keys, enter a 6 digit passcode. The passcode cannot be zeros.



7 When you are done, press **Enter**.

Entering and Exiting Training Mode

After a training passcode is programmed, you can use Training mode. You can exit Training mode by turning the cash register off, moving the Reg key to a position other than Reg, or by entering the exit code.

Note

You cannot enter or exit Training mode if Tables are open or active. For more information about closing or using tables, see Using Tables on page 65.

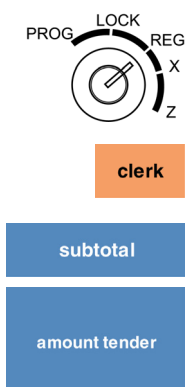

To start Training mode

- 1 Put the REG key in the Mode key slot and turn it to the Reg position.
- 2 If the clerk numbers are set, press the four digit passcode and then press the **Clerk** key.
- 3 Using the Number keys, enter 000987. Press the **subtotal** key.
- 4 Using the Number keys, enter the 6 digit passcode. Press the **Amount Tender** key. The word **Training** appears on the screen.
- 5 Now you can ring up sales in training mode. These sales do not appear in the sales reports.

To stop Training mode

- 1 During Training mode, end any sale in progress.
- 2 Do one of the following:
 - Move the Reg key to another position.
 - Turn the cash register off.
 - Using the Number keys, enter 000789. Press the **subtotal** key.
- 3 Now you can ring up sales normally. These sales appear on sales reports.

Programming Complex Tax Rates

Your cash register can manage complex tax rates and assignments. This chapter explains how to set these up.

About Tax Systems

This chapter explains the more complex tax programming such as Table Tax, Tax Limit, Canadian Tax System and VAT.

Many people do not need the detailed information in this chapter. If this information does not relate to your business needs, you can skip it.

Price and tax calculations use the 5 up and 4 down rounding method. For all calculations creating a value with a longer decimal length than what the current active setting is, the number is rounded accordingly to conform with the setting. Values ending with 5 or more are rounded up and values ending with 4 or less are rounded down.

For example: If 5 gallons of gas are sold at a price of \$2.669 per gallon, the actual cost is \$13.345. Because fractions of cents are not used, this is rounded up to \$13.35.

USA Tax - Choosing Straight Add-On Rate or Table Tax

If you do not know your state's policies regarding collecting sales tax, or you need to obtain your sales tax rate, contact your local government office and ask for your local tax chart.

As mentioned in earlier chapters in this manual about tax programming, for many businesses, programming the sales tax as a straight fixed rate is adequate; however some states and municipalities require the tax rate to be programmed using a tax table code which insures very precise tax calculation.

Tax Limits

Also discussed in this chapter is the Tax Limit setting. The tax limit or base tax amount is the maximum amount up to which no tax is charged. Sometimes this is also called “base tax” or “maximum tax exempt amount”.

By default, your cash register does not set a maximum tax exempt amount or “tax limit”, resulting in all amounts being taxable starting from .01 cent. If your base tax amount is other than .01 cent, program the Tax Limit setting as explained Programming Straight Add-on Tax in the United States on page 73. This Tax Limit setting is available for U.S. Add-On tax when programming a straight fixed rate and also for the Canadian Tax System.

You do not need to reprogram all options if you want to update or change one thing. Save this manual in a safe place so you have it for future programming. After you are done programming, you can print Confirmation Reports to check your results. For more information, see Running Reports on page 86.

Selecting the Tax System

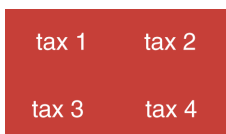

Within the tax system you select, you can program up to 4 different tax rates on your cash register. Each tax rate can be linked directly to a department (see Programming Tax Status on page 35), and overridden by pressing the **Tax 1** to **Tax 4** keys during sales transactions.

Contact your local state government office for your current tax rates.

You must first select one of 3 tax systems:

- Select USA (ADD-ON RATE) - the tax amount is added onto the price of the item sold. Add-on Tax is most common in the United States. Add-on Tax can be programmed as either:
 - straight tax, which charges tax based on a flat percentage rate. For example, 7.75% of the price of the item. This form of add-on tax is most common in the United States.

- tax table codes, which is a calculation based on an approved tax chart issued by your local or state government. This method lists a range of prices and the exact tax for each range. For example, from 11 cents to 24 cents, the tax is 3 cents.
- Select Canadian Tax System - allows you to program the Goods and Services tax (GST) and Provincial Sales Tax (PST) tax system required in Canada.
- Select VAT (Value Added Tax) - includes the tax amount in the price of the item.

You can only use one tax system at a time. After you select the tax system you want to use, you can program up to 4 different tax rates.

When you program a department or PLU, you can select to link 1 or more of these tax rates together.

You can specify that the cash register does not print the tax amount on receipts. For more information, see Printing Parameters Settings on page 49.

To select a tax system

406 -- Options ▶ System Configuration Setting ▶ Tax System

- 1 Put the MGR key in the Mode key slot and turn it to the PROG position. If prompted, enter the Manager passcode and press **Enter**.
- 2 Press the **Arrow Down** key to select 406 -- Options. Press **Enter**.
- 3 Press the **Arrow Down** key to select System Configuration Setting. Press **Enter**.
- 4 Press the **Arrow Down** key to select Tax System. Press **Enter**.
- 5 Select the tax system you want to use.
- 6 When you are done, press the **Cancel** key.

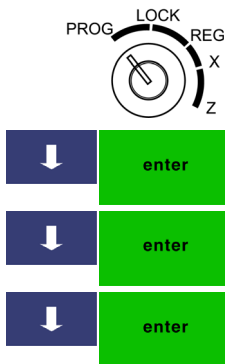

Programming Straight Add-on Tax in the United States

After you select the tax system to use, you must specify values. This section explains how to specify straight add-on tax rates for the United States. Straight add-on tax is the most common in the United States. You may program as few as 1 and up to 4 tax rates.

With this form of tax collection, you can also set a “tax limit”.

To program straight Add-on tax rates for the United States

404 -- Tax Setting

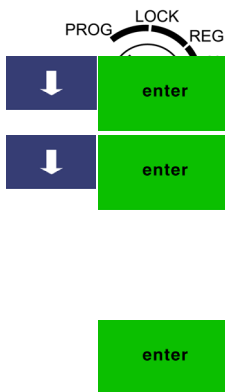

- 1 Put the MGR key in the Mode key slot and turn it to the PROG position. If prompted, enter the Manager passcode and press **Enter**.
- 2 Press the **Arrow Down** key to select 404 -- Tax Setting. Press **Enter**.
- 3 Select the tax (1 to 4) you want to change. Press **Enter**.
- 4 Select the tax item you want to change. You can select Type or Rate.
- 5 Follow the instructions on the screen.
- 6 If needed, specify the tax limit.
- 7 When you are done, press **Enter**.

Programming Table Tax in the United States

If your area uses a tax code table, you must calculate your tax codes before you continue with this section. For instructions, see *Calculating Your Tax* on page 75. When you are done calculating your tax codes, return to this section.

Before you start, you must know where the first **irregular breakpoint** and the first **regular breakpoint** are.

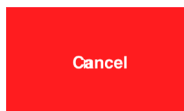

Note

If you make an error when you are entering the price ranges, press **cancel** and start over.

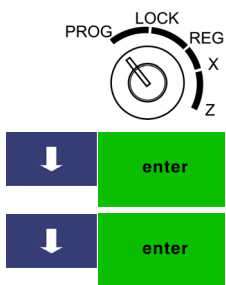

To program table tax rates for the United States

404 -- Tax Setting

- 1 Put the MGR key in the Mode key slot and turn it to the PROG position. If prompted, enter the Manager passcode and press **Enter**.
- 2 Press the **Arrow Down** key to select 404 -- Tax Setting. Press **Enter**.
- 3 Select the tax (1 to 4) you want to program. Press **Enter**.
- 4 Select Type and press **Enter**.
- 5 Press **Enter** to start programming the break points.
- 6 Do the following:
 - Start with the irregular breakpoints.
 - Using your tax chart, enter the price ranges and the amount of tax for each range. Before the start of the **regular repeating breakpoint**, press the **#/NS** key to move to regular breakpoints
 - Continue entering price ranges and the amount of tax for each range until you completely enter an entire sequence of repeating **regular**



breakpoints. Press the **#/ns** key. You return to the Tax selection screen.

7 Repeat for each tax you want to set.

Calculating Your Tax

This section provides instructions for figuring your own tax code if your specific state uses a tax table. Take the time to follow the Example Tax Worksheet on page 77. Familiarize yourself with the method of determining the tax code.

Then, using the worksheet on page 78, duplicate the method of calculating your state tax code by the steps described in this section. To do this you need to get a copy of your state's Retail Tax Chart from your local Tax Office. After you are done, write down the tax code and save the information for future reference.

Every tax table consists of tax brackets. Each consecutive tax bracket is assigned a tax amount which is exactly one cent higher than that assigned to the previous tax bracket. For example, part of a tax chart might look like:

SALES	TAX	SALES	TAX
.00 - .08	.00	9.59 - 9.74	.58
.09 - .24	.01	9.75 - 9.91	.59
.25 - .41	.02	9.92 - 10.08	.60
.42 - .58	.03	10.09 - 10.24	.61
.59 - .74	.04	10.25 - 10.41	.62
.75 - .91	.05	10.42 - 10.58	.63
.92 - 1.08	.06	10.59 - 10.74	.64
1.09 - 1.24	.07	10.75 - 10.91	.65
1.25 - 1.41	.08	10.92 - 11.08	.66
1.42 - 1.58	.09	11.09 - 11.24	.67
1.59 - 1.74	.10	11.25 - 11.41	.68
1.75 - 1.91	.11	11.42 - 11.58	.69
1.92 - 2.08	.12	11.59 - 11.74	.70
2.09 - 2.24	.13	11.75 - 11.91	.71
2.25 - 2.41	.14	11.92 - 12.08	.72
2.42 - 2.58	.15	12.09 - 12.24	.73
2.59 - 2.74	.16	12.25 - 12.41	.74
2.75 - 2.91	.17	12.42 - 12.58	.75

In our Example Tax Worksheet, a sale from .00 to .08 is not taxed. The next tax bracket a sale from .09 to .24 is taxed one cent. The next tax bracket a sale from .25 to .41 is taxed two cents. The tax table progresses in a similar manner.

To calculate your tax rate

1 Using The Worksheet on page 78, complete Step A with the appropriate amounts from your state's Retail Tax Chart.

2 For the following, see the Example Tax Worksheet, Step B:

The difference between the starting amounts of each consecutive tax bracket is called a breakpoint. Every tax table consists of a particular sequence of breakpoints.

In our Example Tax Worksheet, the difference between .00 and .13 is .13 cents. This 13 is the first breakpoint. The difference between .13 and .32 is .19 cents, which means 19 is the second breakpoint.

The breakpoints continue in a particular sequence through the entire tax table.

- Using The Worksheet, complete Step B by calculating the breakpoints based on your state's Retail Tax Chart.
- The sequence of breakpoints is divided into *Regular* and *Irregular* patterns. All tax tables have a pattern of irregular breakpoints that leads into a repeating pattern of regular breakpoints.

To determine the breakpoint pattern, continue calculating the breakpoints in Part B until you have found the Regular repeating breakpoint pattern.

From our example:

Breakpoints 13, 19, 23, 27, 27, 29 are the Irregular breakpoint pattern.
Breakpoints 25, 25, 25, 25 are the Regular repeating breakpoint pattern.

The Regular repeating breakpoint pattern is a point where you first see a repetition of one or more numbers, which then add up evenly to 100, 200, 300, and so on. In our programming example, the Regular breakpoint pattern (25, 25, 25, and 25) adds up to 100.

It is possible that your specific regular breakpoint pattern can never add up to 100, 200 or 300. For example, your regular breakpoint pattern may be 33. In this case, make sure you enter **at least 4** examples of the regular breakpoint pattern.

Using The Worksheet on page 78, determine the Regular breakpoint pattern based on your state's Retail Tax Chart.

Example Tax Worksheet

The following is an example of how a tax table worksheet can look.

Note

A total of 63 breakpoints can be programmed on this cash register.

		STEP A			
		SALE AMOUNT		TAX AMOUNT	
STEP B		from	to		
Breakpoints		0	12	0	Enter these values when you set the table tax
	13	13	31	1	
	19	32	54	2	
Irregular breakpoints (no pattern)	23	55	81	3	
	27	82	108	4	
	27	109	137	5	
	29	138	162	6	Press the #/NS key before you enter the first values for the first regular breakpoint
Regular breakpoints (at least 4 examples of the pattern)	25	163	187	7	
	25	188	212	8	
	25	213	237	9	
	25	238	---	10	After at least 4 examples of the regular breakpoint, press the #/NS key again

Use the worksheet on the next page to calculate the irregular breakpoints and regular breakpoints for your local tax.

The Worksheet

Follow your tax chart and write down your results here.

STEP A

SALE AMOUNT

<u>STEP B</u>	SALE AMOUNT		TAX
	from	to	AMOUNT
Breakpoints			

Using Canadian Tax Rates

If you are in Canada, this cash register can be set for Canadian tax rates. If you are using Canadian tax rates, you see the following 4 tax rate options:

- GST
- PST1
- PST2
- PST3

For each tax rate (GST, and each PST), in addition to setting the tax percentage rate, you can also set a “tax limit”. Set this amount when setting the tax percentage amount. Just follow the instructions on the screen.

You can also set Tax-On-Tax or Piggy Back Tax.

To set the cash register to GST/PST (Canadian tax) format

406 -- Options ▶ System Configuration Setting ▶ Tax System

- 1 Put the MGR key in the Mode key slot and turn it to the PROG position. If prompted, enter the Manager passcode and press **Enter**.
- 2 Press the **Arrow Down** key to select 406 -- Options. Press **Enter**.
- 3 Press the **Arrow Down** key to select System Configuration Setting. Press **Enter**.
- 4 Press the **Arrow Down** key to select Tax System. Press **Enter**.
- 5 Select GST-PST.
- 6 When you are done, press **Cancel**.

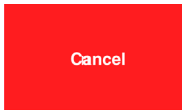
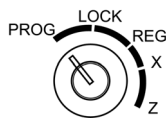

To set Canadian tax rates

404 -- Tax Setting

- 1 Put the MGR key in the Mode key slot and turn it to the PROG position. If prompted, enter the Manager passcode and press **Enter**.
- 2 Press the **Arrow Down** key to select 404 -- Tax Setting. Press **Enter**.
- 3 Select the item you want to program. Press **Enter**.
- 4 Select the rate or limit amount to be changed and press **Enter**.
- 5 Follow the instructions on the screen.
- 6 When you are done, press the **Cancel** key.

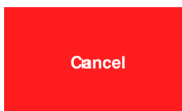
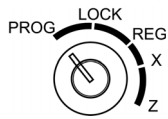

To set Tax-on-Tax

- 1 Put the MGR key in the Mode key slot and turn it to the PROG position. If prompted, enter the Manager passcode and press **Enter**.
- 2 Press the **Arrow Down** key to select 404 -- Tax Setting. Press **Enter**.
- 3 Press the **Arrow Down** key to Tax-on-tax. Press **Enter**.

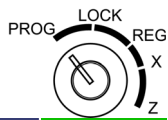



- 4 Make your selection and press **Enter**.

Using VAT Tax Rates

The Value Added Tax is commonly used in Mexico and Europe, as well as other locations.

To set the cash register to use VAT tax

404 -- Tax Setting ▶ System Configuration Setting ▶ Tax System

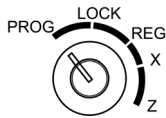

- 1 Put the MGR key in the Mode key slot and turn it to the PROG position. If prompted, enter the Manager passcode and press **Enter**.



- 2 Press the **Arrow Down** key to select 404 -- Tax Setting. Press **Enter**.



- 3 Select the tax you want to change. Press **Enter**.

- 4 Using the number area, enter the tax rate to set using a 5 digit code. Press **Enter**.

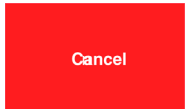

- 5 Repeat for each tax you want to set.

- 6 When you are done, press the **Cancel** key.

To set a VAT tax

404 -- Tax Setting ▶ System Configuration Setting ▶ Tax System

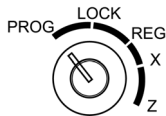

- 1 Put the MGR key in the Mode key slot and turn it to the PROG position. If prompted, enter the Manager passcode and press **Enter**.



- 2 Press the **Arrow Down** key to select 404 -- Tax Setting. Press **Enter**.

- 3 Select the tax you want to change. Press **Enter**.



- 4 Using the number area, enter the tax rate to set using a 5 digit format. Press **Enter**.

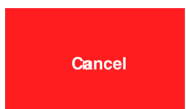

- 5 Repeat for each tax you want to set.

- 6 When you are done, press the **Cancel** key.

Printing a Confirmation Report

To check your results, see Options Dump Report on page 56.

Running Reports

Your cash register includes many reports. In this chapter, we explain:

- Programming confirmation reports
- Department confirmation reports
- PLUs confirmation reports
- Clerk confirmation reports
- Financial reports, such as sales totals and End-of-Day (Z) reports
- Other management reports
- Electronic Journal reports

You can view reports on the screen or print them. You can also clear a report after you view it on the screen. Clearing a report in Z mode removes the data for that report from the cash register.

When you are printing a report, do not try to change mode key positions or attempt any other task with the cash register.

Note

Make sure you have a lot of cash register paper installed before you start printing any report. You can stop printing by pressing **Cancel**.

Cancel

Running the Department Confirmation Report

You can print a report that shows the active information for all programmed departments.

To run a department confirmation report

401 -- Department Set Up ▶ Print All Programmed Dept

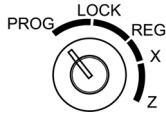

- 1 Put the MGR key in the Mode key slot and turn it to the PROG position. If prompted, enter the Manager passcode and press **Enter**.
- 2 Press the **Arrow Down** key to select 401 -- Department Set up. Press **Enter**.
- 3 Press the **Arrow Down** key to select Print All Programmed Dept. Press **Enter**.

Running the PLU Confirmation Report

The PLU Confirmation Report allows you to check all PLUs programmed. For more information about programming PLUs, see Programming PLU Descriptions on page 38.

To run the PLU confirmation report

402 -- PLU Setting ▶ Print PLU Parameters

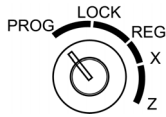

- 1 Put the MGR key in the Mode key slot and turn it to the PROG position. If prompted, enter the Manager passcode and press **Enter**.
- 2 Press the **Arrow Down** key to select 402 -- PLU Setting. Press **Enter**.
- 3 Press the **Arrow Down** key to select Print PLU Parameters. Press **Enter**.

Running the Clerk Confirmation Report

You can print a list of all clerks that shows their name and passcodes.

To print a clerk report

403 -- Clerk Setting ▶ Print Programmed Clerks

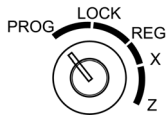

- 1 Put the MGR key in the Mode key slot and turn it to the PROG position. If prompted, enter the Manager passcode and press **Enter**.
- 2 Press the **Arrow Down** key to select 403 -- Clerk Setting. Press **Enter**.
- 3 Press the **Arrow Down** key to select Print Programmed Clerks. Press **Enter**.

Running Management Reports

The cash register maintains totals of all transaction information. This information is saved in the memory of the cash register as long as the register is plugged in to an electrical outlet or, if the cash register is unplugged, the battery is charged.

Management reports show you information about how sales are progressing. You can run all reports as X reports and run some reports as Z reports.

- Run X reports during the day to check transactions or running totals. These reports do not clear the transaction memory in the cash register. You can run all reports in the X mode. See About X Reports on page 83.
- Run Z reports at end of day, end of the week, or end of the month. These reports **CLEAR** the transaction memory in the cash register and reset all totals to zero. When you are done printing these reports, the information only exists on the cash register tape. You can run almost all reports in the Z mode. See About Z Reports on page 85.

To prevent someone from accidentally printing these reports, you can set a manager passcode for X reports and a manager passcode for Z reports. After the passcode is set, you are prompted for a passcode to access these reports. For information about setting manager passcodes, see Setting X and Manager Passcodes on page 30.

About X Reports

X reports do not clear the transaction memory in the cash register. There are 2 kinds of X reports.

- Daily report - Commonly known as a *mid-day* reading. Use this report to print periodic readings of transaction totals during the course of the day. This report does not reset to zero.
- PTD reports (Periodic to Date) - Commonly known as a *mid-week* or *mid-month* readings. Use this report to print periodic readings of transaction totals during the course of several days. This report does not reset to zero.

The available X reports are:

- | | |
|------------------------------|---|
| • 1 - Daily Full Report | Shows all transaction data and sales totals. |
| • 2 - Daily Dept Full Report | Shows quantity and dollar amount of each department number rung up today. |

- 3 - Daily Dept Group Report Shows quantity and dollar amount of the specified department group rung up today.
- 4 - Daily PLU Full Report Shows quantity and dollar amount of each PLU number rung up today.
- 6 - Daily Clerk Report Shows total sales amounts of each Clerk Number.
- 7 - Hourly Report Shows total sales amounts rung up each hour.
- 11 - PTD Full Report Shows each department number, total items sold, dollar amount, and net sale amount rung up, either weekly or monthly.
- 12 - PTD Dept Full Report Shows department, quantity, dollar amount, total of each department number rung up over a period of time.
- 13 - PTD Dept Group Report Shows the specified department, quantity, dollar amount, and total sale amount, either weekly or monthly.
- 14 - PTD PLU Full Report Shows quantity and dollar amount of the specified group number rung up since the report was last cleared.
- 15 - PTD PLU Group Report Shows quantity and dollar amount of each PLU group number rung up since the report was last cleared.
- 16 - PTD Clerk Report Shows total sales amounts of each Clerk Number, either weekly or monthly.
- 51- Table Report Shows total sales amounts for each table since last clear.
- 52 - Active Table Report Shows information about active tables, including assigned clerk. Also viewable in Reg mode.
- 101 - PLU Inventory Report Shows the programmed PLUs and their current stock level.
- 201 - EJ Report (full) Shows/prints the information in the Electronic Journal.
- 202 - EJ Report by Date Shows the information in the Electronic Journal, by specified date range.
- 210 - Individual PLU Report Shows quantity and dollar amount of a specific PLU.

- 211 - Individual Clerk Report Shows total sales amounts of each Clerk. Input the clerk number to see specific sales.
- 212 - Individual Dept Report Shows the sales information, quantity, and dollar amount totals for the specified department.
- 222 - Cash TTL in Drawer Report Shows how much cash is in the drawer at the time of the report.

About Z Reports

Z reports clear the transaction memory in the cash register and reset all totals to zero. There are 2 kinds of Z reports.

- Daily report – Commonly known as a *end-of-day/daily-closeout* reports. These reports show transaction data and resets all totals to zero, except the Running Grand Total.

You can print duplicate Daily reports. This is useful if the register runs out of paper or if there is a power outage while a Daily report is printing. However, you must set the parameter in Others to allow a second report to be printed. For more information, see 406 Options on page 49.

- PTD reports (Periodic to Date) – Commonly known as a *weekly* or *monthly* readings. PTD reports show transaction totals either on a weekly or monthly basis (not both) and resets all transaction totals to zero except the Running Grand Total.

The available Z reports are:

- 1 - Daily Full Report Shows transaction data and resets all totals to zero, except the Running Grand Total.
- 4 - Daily PLU Full Report Shows quantity and dollar amount of each PLU number rung up today.
- 7 - Hourly Report Shows the total sales amounts rung up each hour.
- 11 - PTD Full Report Shows weekly or monthly transaction data and resets all totals to zero, except the Running Grand Total.
- 14 - PTD PLU Full Report Shows quantity and dollar amount of each PLU number rung up since the report was last cleared.

- 16 - PTD Clerk Report Shows total sales amounts of each Clerk Number since the report was last cleared.
- 51 - Table Report Shows total sales amounts for each table since the report was last cleared.
- 201 - EJ Report (full) Shows the information in the Electronic Journal. Clears the EJ after printing.
- 221 - Clear Grand Total Clears the running grand total
- 223 - Second Z Sales Report Prints (only) a duplicate copy of all Daily Full reports printed since the last second report was accessed. This function must be activated before you can use it.

Running Reports

Running reports is easy - just follow the prompts on the screen. You can view or print a report.

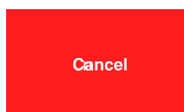

Note

Make sure you have a lot of cash register paper installed before you start printing any report. You can stop printing a report by pressing the **cancel** key.

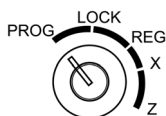

To run reports

1 Put the MGR key in the Mode key slot and turn it to the X or Z position, depending on which report you want to see. If prompted, enter the Manager passcode and press **Enter**.



2 Press the **Arrow Down** key to select the report you want. Press **Enter**.

The report appears on the screen. Use the Arrow keys and the **Page up** and **Page down** keys to move through the report. You can print the report or clear it, using the options on the screen.

Financial Report Example

Totals are calculated for the Management Reports in the following way.

NET SALES AMOUNT - Shows the total of all sales registered. The Net Sales Amount includes all:

- department sales totals (Total), coupon (Coupon)
- percentage add-ons/discounts (%1, %2, %3),
- tax totals (Tax1-4)

- return/refunds (R.M./Refund)
- voids (E.C., VOID, Trans void).

Minus percentage discount (DISCOUNT), voids (VOID/CORR) and returns/refunds (REFUND) are all deducted from the department totals and the plus percentage (ADD ON) is added to the department totals, depending on the parameter settings.

The Financial report looks like the following. Your specific report looks different, because of your unique cash register activity. Your actual report may vary slightly.

Z number	1	—	Z counter

Item Name	Count	Amount	
=====			
DEPT001	4	234.17] Department totals
DEPT002	3	432.00	
DEPT003	4	254.33	
DEPT004	1	632.59	

Total	12	1553.09	=====
%1		-15.000%	===== Discount/add-on names and rates
* SubT *	1	-45.00	===== Subtotal or items-based totals (separate listings)
Coupon	1	-100.00	===== Coupons and amounts
Tax1		10.000%] Tax rates, taxable totals, and taxes collected
Taxable amt		488.50	
Amt		49.85	
Tax2		20.000%	
Taxable amt		686.33] Total tax amount collected
Amt		137.26	
Total tax amount		187.11	=====
Net sales w/o tax		1453.09	===== Net sales not including tax
Net sales amount		1640.20	===== Net sales including tax
Total Transactions	5		===== Total number of transactions

Refund Information			
Refund Cash	1	25.00] Refund totals by payment method

E.C.	1	25.00] EC/Void/Trans Cancel
VOID	1	-10.00] EC/Void/Trans Cancel

* Received on account **			
Cash	1	1500.00] RA by payment method
Check	1	500.00] RA by payment method
Charge	1	200.00] RA by payment method
***** Paid Out *****			
Cash	1	-500.00] PO by payment method
Check	1	-10.00] PO by payment method
Charge	1	-20.00] PO by payment method

Cash Sale	2	1113.24] Sales by payment method
Credit Sale	1	114.50] Sales by payment method
Check	2	412.40] Sales by payment method

Check total in drawer		412.40] In-drawer totals
Cash total in drawer		2088.24	
Grand total		14681.38	=====

01-02-2006	05:20 PM	—	Date and time run

More Information about the Electronic Journal (EJ) Reports

The Electronic Journal records in the internal memory the line-by-line details of all the transactions and items completed on the cash register, both transactions printed on the built-in printer and transactions run with the printer off and no receipt printed. This includes all sales transactions, and using the **#/NS** key for no-sale rings to open the cash drawer.

The Electronic Journal can hold 10,000 lines of transactions in memory. When the Electronic Journal has 9,500 lines of transactions in memory, you see an error message after finalizing every transaction. Print or clear the Electronic Journal as soon as possible to avoid losing important information.

Sales totals will still be recorded in the financial or sales reports. Transactions already in memory are kept in memory until the Electronic Journal record is printed in Z-mode or until you clear the report.

Caution

When the Electronic Journal memory is full, you see a message that the memory is being cleared. At that point, all your transaction data is cleared and transactions start over again from zero. You lose all the electronic history of transactions.

You can print the entire Electronic Journal record on the printer in the cash register in either the X Mode or the Z Mode.

- **X-Mode:** You can print the Electronic Journal record at any time during the day. This prints what is currently in the Electronic Journal memory and **does not** reset the memory. You can also review the electronic journal on the clerk screen. You can also run an EJ report by date, if needed.
- **Z-Mode:** You can view, print, or clear the entire Electronic Journal record. Clearing resets the journal memory so everything in memory is erased. Only run this report at the end of the day, after running the standard Z Report for the end-of-the-day sales totals.

Make sure there is a lot of paper on the receipt paper roll so the Electronic Journal reports can print completely.

You can download the Electronic Journal record to the PC using the serial connection. For more information, see the RegisterLink manual.

Print a Mid-Day Electronic Journal Report

You can print the Electronic Journal report at anytime during the day without resetting the memory. You can run an EJ report for a specific date or time period.

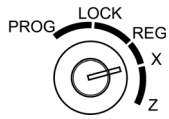

To print X reports

X Report

- 1 Put the MGR key in the Mode key slot and turn it to the X position. If prompted, enter the Manager passcode and press **Enter**.
- 2 Press the **Arrow Down** key to select the report you want. Press **Enter**.
- 3 You can review the report on the clerk screen and then print it. Use the arrow keys to go to the beginning or end of the report. Use the page up and down keys to move line by line through the report.



Print an End-of-Day Electronic Journal Report

You can print the Electronic Journal Z report at the end of the day. This report prints all transactions and clears the memory at the same time.

To print Z reports

Z Report

- 1 Put the MGR key in the Mode key slot and turn it to the Z position. If prompted, enter the Manager passcode and press **Enter**.
- 2 Press the **Arrow Down** key to select the report you want. Press **Enter**.
- 3 You can review the report on the clerk screen and then print it. Use the arrow keys to go to the beginning or end of the report. Use the page up and down keys to move line by line through the report.

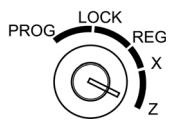

Check the Electronic Journal Memory

You can check the current status of the Electronic Journal memory for the number of lines used in memory and how many lines remain free. This lets you know if you should print the Electronic Journal soon.

If you do not see the number of lines that the memory can still accept, the Electronic Journal is turned off. Go to 406 -- System Options and turn it on.

To check the Electronic Journal memory

407 -- Others ▶ 426 -- System Information

- 1 Put the MGR key in the Mode key slot and turn it to the PROG position. If prompted, enter the Manager passcode and press **Enter**.
- 2 Press the **Arrow Down** key to select 407 -- Others. Press **Enter**.
- 3 Press the **Arrow Down** key to select 426 -- System Information. Press **Enter**.

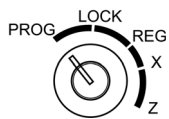

The total available number of Departments, PLUs, and Clerks are shown with the number you are using. You also see the EJ information. If the number used is close to the total number of 10,000, print the EJ report to avoid losing important information.

For information about EJ errors, see Electronic Journal Memory Errors on page 96.

Maintenance and Options

Follow these steps to keep your cash register in good working order.

- Your register must remain uncovered when turned on. This allows the electronic components to properly cool.
- Use a dust cover when the register is not in operation and the cash register is set to the OFF position to protect mechanical components from dust.
- Keep beverages and other liquids away from the machine to avoid spills which can damage electronic components.
- Keep the cash register away from dust, dampness, or extreme hot or cold temperatures.
- To clean your cash register, use a soft dry cloth.
- After storing your cash register in extreme temperatures (below 32 degrees Fahrenheit or above 104 degrees Fahrenheit), allow the temperature inside the machine enough time to reach room temperature before turning it on.
- If you need electronic service, take the cash register to a Royal authorized service center. For more information, see Manufacturer's Limited Warranty on page 125.
- Do not attempt to open or repair the cash register yourself. There are no end-user serviceable parts in the cash register and it should only be opened or serviced by an authorized service representative. Attempting to service the cash register yourself voids the warranty and may permanently damage the cash register.

Cleaning the Touch Screen

As you use your cash register, you may need to clean the touch screen. Use a small amount of rubbing alcohol and a soft cloth in a well ventilated area to gently clean the touch screen. For best cleaning results, use a dust free cotton cloth.

Caution

Never use Windex or other household cleaner on the touch screen. Household cleaners can permanently damage the touch screen.

To clean the touch screen

- 1 Turn off the cash register.
- 2 If needed, move the cash register to a well ventilated location, away from fire or sources of heat.
- 3 Put a small amount of rubbing alcohol on a soft cloth.
- 4 Gently wipe an area of the touch screen with the damp cloth.
- 5 Repeat until the touch screen is clean.
- 6 When the screen is dry, the cash register is ready to be used again.

Installing a Replacement Paper Roll

As you use the cash register, you will need to replace the paper roll. Your cash register has a thermal printer that prints receipts for the customer. Use 2¼ inch (57.5 mm) wide standard thermal register paper. Do not use bond paper because the register does not use a ribbon or ink for printing.

Caution

Do not manually pull the receipt paper. Always use the Feed key to remove or advance the paper. Never use sharp or pointed instruments in the printer area. This can seriously damage the printer.

To replace the paper roll

- 1 Open the receipt printer cover.

- 2 Unwrap the paper roll. Place the paper roll in the paper well with the paper feeding from the bottom.
- 3 Grab the small handle on the right of the print head. Flip the little handle towards the front of the printer.
- 4 Feed the end of the paper into the slit under the print head.
- 5 Flip the little handle towards the back of the printer.
- 6 Press the **Feed** key to move the paper through the printer to make sure there is no jam and the paper is properly installed before continuing.
- 7 Feed the paper through the paper slot in the printer cover.
- 8 Close the printer cover.

feed

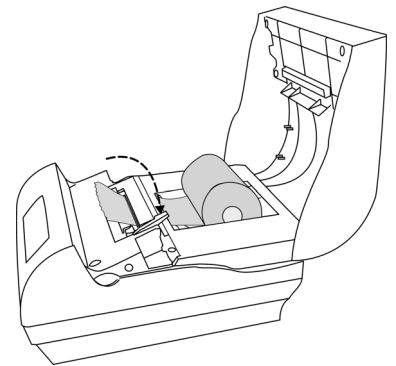
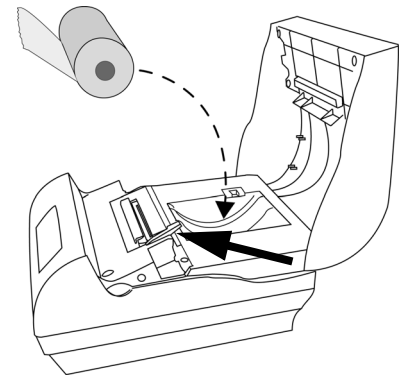
**Note**

Make sure the thermal paper feeds from the correct position or printing errors will occur.

About the Serial Port

Your cash register includes 3 serial ports on the cash register. You can connect items to the cash register using these serial ports. You can connect the receipt printer, a PC, an optional barcode reader, or a secondary/backup printer.

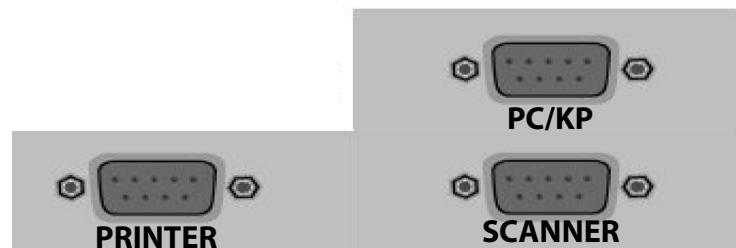

The receipt printer connects to the serial port labeled PRINTER. To use the optional barcode reader, connect it to the serial port labeled SCANNER. You can use the serial port labeled PC/KP to connect the cash register to:

- a second printer

- a PC to use the RegisterLink software

To connect your computer to the serial port, you need a specific null-modem serial cable. A 6 foot null modem serial cable is included in the box with the cash register to use with the receipt printer. If it is lost or damaged, contact Royal for a replacement.

The pin description for all serial ports on the cash register is shown below.

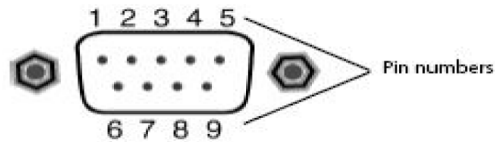

Table 8 Serial port pin description

Pin No	I/O	Signal name	Abbr.
1	NC		
2	IN	Receive data	RXD
3	OUT	Transmit data	TXD
4	NC		
5	N/A	Ground Signal	GND
6	NC		
7	NC		
8	NC		
9	+5V OUT	Power supply for BCR	VCC

Connecting the Cash Register to a PC

Using the RegisterLink software, you can connect your cash register to a PC to download the information.

Note

You must use RegisterLink version M or later.

RegisterLink must be installed and the PC restarted if it was the first time you installed RegisterLink. For specific information about using the RegisterLink software, see the RegisterLink manual.

Before you start, you must have the null modem serial cable that came with your cash register.

To set up the cash register to connect to a PC

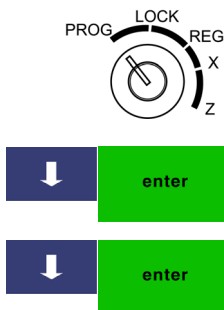

- 1 Connect the cash register to the PC using a null modem serial cable.
- 2 Open the RegisterLink software on your PC.
- 3 Put the MGR key in the Mode key slot and turn it to the PROG position. If prompted, enter the Manager passcode and press **Enter**.
- 4 On the cash register, press the **Arrow Down** key to select 407 -- Others. Press **Enter**.
- 5 Press the **Arrow Down** key to select 423 -- PC Communication. Press **Enter**.
- 6 Go to the RegisterLink software on the PC and follow the directions in RegisterLink.

About the Battery

Your cash register comes with a factory installed rechargeable battery that should last about 3 years. The battery fully charges after the cash register is plugged in for about 12 hours.

The battery maintains the information in the cash register, such as programming and transaction data, for at least 60 days if the cash register is unplugged. You **cannot** run the cash register on the backup battery.

Only a factory trained service technician can replace the battery.

Troubleshooting

Most errors are described on the clerk screen and you are prompted with the action to take. This section generally describes other possible issues and what to do. Select and follow the procedure which best describes what is happening.

Paper End or Other Printer Errors

These errors mean there is a paper problem.

Caution

Do not manually pull the receipt paper. Always use the Feed key on the receipt printer to remove or advance the paper. Do **not** use sharp or pointed instruments in the printer area. This can seriously damage the printer.

- Check if you are out of paper. If so, replace with a new roll.
- Check for a paper jam. If so, carefully remove any paper obstructing the printer.
- Check and make sure the paper was aligned properly in the printer and that the printer handle is in the locked position.
- After the paper problem is solved, press the **return** key. If an error message still appears, unplug the cash register, wait 10 seconds, and plug it back in.

A blue rectangular button with the word "return" written in white lowercase letters.

No Receipt Printing

If the cash register is not printing on the receipt, check the Print Receipt option. Go to 406 -- Options and then select Printing Parameters Settings.

No Printing on the Receipt

If the cash register is set to print the receipt and no receipt is printing, make sure you are using **thermal paper** and the paper is installed correctly. For more information about correctly installing the paper, see *Installing a Replacement Paper Roll* on page 91.

Bond paper will not work in this cash register. If needed, contact the Royal Customer Support hotline at 1-800-272-6229 for additional help.

The Cash Register Screen goes Dark

This is normal. This cash register has a “go to sleep mode” that turns the cash register off after a specified time period. You can start the cash register again by touching the screen.

Note

If you have a barcode reader attached, you cannot wake the cash register up by trying to use the barcode reader. You must touch the screen.

For more information, see *Using Power Saving Mode* on page 17.

Electronic Journal Memory Errors

If the Electronic Journal gets too full, you see an error message after each sale is finalized. Check the Electronic Journal occasionally to see if you need to run the EJ report. For more information, see *More Information about the Electronic Journal (EJ) Reports* on page 88.

Immediately after the current transaction is finished, either print the Electronic Journal record in Z Mode or manually clear the Electronic Journal record memory. This section explains how to do both.

Before you start, make sure there is a lot of paper on the receipt paper roll so the Z Electronic Journal reports can print completely.

To print and clear the Electronic Journal

201 -- EJ Report

- 1 Put the MGR key in the Mode key slot and turn it to the Z position.
- 2 If you are prompted for a passcode, enter the 6 digit Z passcode and press **Enter**.
- 3 Press the **Arrow Down** key to select EJ Report (full). Press **Enter**. Follow the instructions on the screen.
- 4 Do one of the following:
 - Press **Print Report** to print the report and clear the Electronic Memory.

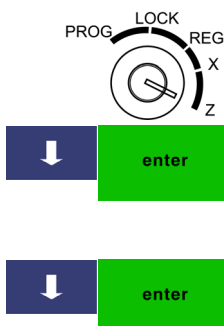

- Press **Clear Report** to clear the Electronic Memory without printing.

The Electronic Journal memory is reset and all information stored in the memory is erased. A verification appears on the screen that the Electronic Journal reset and the memory is cleared.

The Cash Register Does Not Work at All

- 1 Be sure the cash register is plugged into a working electrical outlet and no other electrical device is using the same power source. Another electrical motor on the same circuit can keep the cash register from working properly.
 - Perform a Partial Reset. See Performing a Partial Reset on page 98.
 - As a last resort, perform a Master Reset. See Performing a Master Reset on page 98.
- 2 If needed, contact the Royal Customer Support hotline at 1-800-272-6229 for additional help.

Opening the Cash Drawer When There is no Power

If there is no power and you need to open the cash drawer, follow these instructions.

To open the cash drawer when there is no power

- ◆ Insert the key labeled 777 and turn it to the left. The cash drawer opens.

- or -

- 1 With both hands on the cash drawer, carefully tip the front of the register up. Underneath the cash register, toward the back of the register, you see a small lever.
- 2 Push the lever in the only direction it will move. The cash drawer opens.

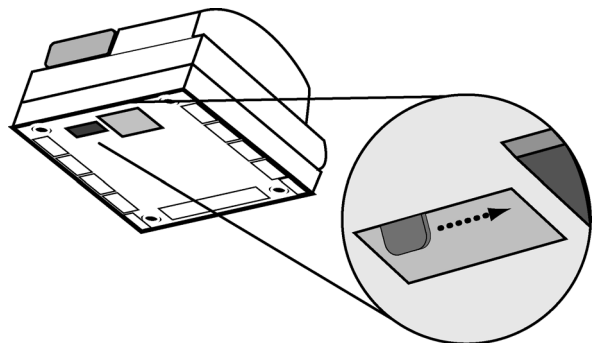

Performing a Partial Reset

If you are in the middle of a transaction when you do a partial reset, when the cash register powers back on, that transaction must be finalized before you can move forward.

To do a partial reset

- 1 Turn off the cash register.
- 2 Slowly count to 3.
- 3 Turn the cash register back on.
- 4 Continue with normal operations.

Performing a Master Reset

If nothing else works, perform the following procedure.

Caution

This procedure resets the cash register to the factory settings. You lose all your transaction and programming information.

Before you start, make sure you have the stylus that came with the cash register.

To do a full system clear

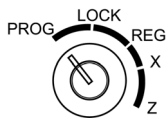

- 1 Turn off the cash register.
- 2 Put the MGR key in the Mode key slot and turn it to the PROG position.
- 3 Turn on the cash register.
- 4 When the *System Initializing* message appears on the screen, quickly press the lower left corner and the upper right corner of the screen with your thumbs. The cash register beeps and the printer prints a confirmation message.
- 5 Using the stylus and following the onscreen instructions, press the 2 points to reinitialize the screen.
- 6 Reprogram the cash register.

If Nothing Helps

If a problem still persists, call our Customer Service Support Line toll-free at 1-800-272-6229.

Error Messages

Error messages may appear on the clerk screen when you are performing various functions or to alert you about a machine condition. These errors consist of an error code number and message.

Many messages are easy to understand and self-explanatory. Some error messages may occur in more than one situation. Listed below are some of the common messages you might see when operating the register.

Remember, these are just some of the error messages that may appear.

Note

When any error message occurs, you must acknowledge and clear the message from the screen by pressing the **Return** key.



Table 9 Common error codes

Error Message	Why did it happen?	What to do
E001 Invalid Entry	Can occur in Program, Register and X/Z modes if you enter too many digits, too few digits, or a value that is out of range for a particular function.	Try reentering the value. Screen prompts alert you to the number of digits allowed. If problem persists, verify the minimum or maximum allowable digits for the specific function you are trying to perform.
E002 Wrong Key	Means the wrong key was pressed when performing a specific function. Can occur in Program, Register and X/Z modes.	The Clerk display prompts you when you are performing certain functions for the information that needs to be entered. If needed, see other sections in this manual for the proper key sequences.
E063 Sales Transaction did not end	Occurs anytime a transaction in register mode did not finalize or end and the control lock key was changed to another position.	Return control lock key to register mode and complete the sale with the method of payment, such as cash, check, charge, and so on. Then change the key position to another mode as needed.
E111 Invalid Table Number	Indicates that a table number was entered that is not in the range of 1 – 50.	Reenter the table number using numbers from 1 – 50.

Table 9 Common error codes (continued)

E115 Selected Table is not active	When transfer table function is used, if the source table number entered has not been opened or activated, this message occurs.	The source table must be opened before it can be transferred. See Transferring Tables on page 66 for more information.
E120 Existing Active Table	Occurs if attempting to print/clear a Z report when an active table report has open tables that have not yet been closed out.	Z report can be done after all active tables are closed out with method of payment.
E256 - EJ Nearly Full, Please clear	Indicates that the electronic journal (EJ) memory has reached 9,500 lines. The maximum capacity is 10,000 lines. When the EJ reaches 9,500 lines, this error message appears at the end of each sales transaction until the EJ is cleared.	Finish the current transaction. Print and clear the EJ as soon as possible to avoid loss of all data. After EJ reaches 10,000 lines, the EJ clears automatically. You can check the EJ status in Program mode in Others – System Information (426). EJ shows amount available (10,000) and amount used.
E258 - EJ was full and has been cleared.	Indicates that the electronic journal (EJ) memory reached 10,000 lines and automatically cleared.	No action is required at this point. You can check the EJ status can anytime in Program mode in Others – System Information (426). EJ shows amount available (10,000) and amount used.
Paper End, Install please	Paper is near the end of the roll. This error appears at the start of each transaction or report printing until the paper roll is replaced.	Install a new paper roll and press Clear to continue.
Power Interrupted Error Prints on Receipt Printer	If the register is turned off in the middle of a sales transaction, when turning the power switch back on, this message prints on the receipt.	Return control lock key to Register mode and complete the transaction with method of payment, such as cash, check, charge, and so on. Then change key position to another mode as needed.

Examples

The examples in this section show you how to ring up different types of transactions. You can enter a maximum of 7(99999.99) digits to enter a price, including dollars and cents.

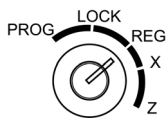

To ring up a sale

- 1 Put the REG key in the Mode key slot and turn it to the Reg position.
- 2 If the clerk passcodes are set, enter the four digit passcode and then press **clerk** .
- 3 You are ready to ring up a sale.

Reminder

Do not press the **Decimal Point** key when ringing up a price.

The following examples are in this chapter.

- Adding Tax to a Non-Taxable Department
- Active Table Pickup
- Bill Print
- Cash Sale With Tendering Change
- Cash Sale Without Tendering Change
- Charge Sale
- Credit/Charge Refund
- Check Sale

-
- Cooking Messages
 - Coupon Discount Sale
 - Credit Sale
 - Dept Shift Button and Departments above 40
 - Direct (Hard) PLUs
 - Exempting Tax On An Item
 - Exempting Tax on the Entire Sale
 - Foreign Currency Sale
 - Gallonage Sales Transaction
 - Minus Percentage Discount Sale
 - Misc. Sale
 - Multiplication of a Department Unit Price
 - Multiplication Sale and Overriding a Preset Department Price
 - Multiplying By A Fraction
 - No-Sale Function (Opening the Cash Drawer)
 - Opening and Closing Tables
 - Paid-Out Sale
 - PLU Sale
 - Plus Percentage Sale
 - Received-On-Account Sale
 - Registering a Department Unit Price
 - Registering a Reference Number/Message
 - Return Sale
 - Refunding Cash
 - Split Tendering Sale
 - Transferring Tables
 - Using the Error-Correct /Void Button
 - Voiding a Department Preset Price
 - Voiding a Multiplication of a Department Preset Price
 - Voiding a Department Multiplication Sale
 - Voiding a PLU Sale
 - Voiding a PLU Multiplication Sale
 - Voiding an Entire Sale before Finishing the Sale
 - Voiding a Sale

Transaction Codes

The following codes appear on transaction receipts:

Table 10 Transaction Codes

This code...	Means this...
NO SALE	No-Sale Function or Open Cash Drawer
E.C.	Error Correct
R.M.	Return Merchandise
VOID	Department/Item Void
@	Amount Being Multiplied
%1, %2, %3	Plus or Minus Percent (may appear differently, depending on what it was programmed as)
CASH	Cash Transaction Total
CHANGE	Change
CHARGE	Charge Transaction Total
CHECK	Check Transaction Total
Clerk #1 to Clerk #40	Clerk number 1 to clerk number 40 (may show names, if names are programmed instead)
CREDIT	Credit card transaction (can be modified)
PAID OUT	Paid Out
Received on Account	Received on Account
REFUND	Refund
SUB	Subtotal (Excludes Tax)
Tax1/T1	Tax 1 Rate Applied to a Sale
Tax2/T2	Tax 2 Rate Applied to a Sale
Tax3/T3	Tax 3 Rate Applied to a Sale
Tax4/T4	Tax 4 Rate Applied to a Sale
TOTAL	Total of Sale
TOTAL TAX AMOUNT	Total Tax Amount

Sample Receipt

The example below shows the general transaction information you see printed on a receipt. Your actual receipt may vary.

	<pre> * YOUR RECEIPT * * THANK YOU * * * Item Name Total ===== DEPT001 \$1.00 T1 DEPT002 \$2.00 T2 DEPT003 \$3.00 DEPT004 \$4.00 ----- SUB \$10.00 Tax1 \$0.07 Tax2 \$0.20 Tot tax amt \$ 0.27 ----- TOTAL \$10.27 Cash \$15.00 Change 4.73 Total Qty 4 07-02-2007 04:08 PM Clerk01 0001 #0004 HAVE A NICE DAY PLEASE COME AGAIN </pre>	<p>Header Message (5 lines) Standard Character 24/line Double-wide character 12/line</p>
Department names	<pre> DEPT001 \$1.00 T1 DEPT002 \$2.00 T2 DEPT003 \$3.00 DEPT004 \$4.00 </pre>	Department items
	<pre> SUB \$10.00 Tax1 \$0.07 Tax2 \$0.20 Tot tax amt \$ 0.27 </pre>	<p>Subtotal Tax 1 amount Tax 2 amount Total Tax</p>
Sales transaction total	<pre> TOTAL \$10.27 </pre>	Cash amount tendered
Change for the customer	<pre> Cash \$15.00 Change 4.73 </pre>	Change Computation
Clerk number, machine number and transaction number	<pre> Total Qty 4 07-02-2007 04:08 PM Clerk01 0001 #0004 </pre>	<p>Total # of items Date and time</p>
	<pre> HAVE A NICE DAY PLEASE COME AGAIN </pre>	<p>Footer Message Standard Character 24/line Double-wide character 12/line</p>

The rest of this chapter shows you example transactions.

Adding Tax to a Non-Taxable Department

Example 1: Assume the Department 2 key is programmed for no tax and the TAX 1 rate is programmed for 6%. Ring up a \$1.00 item in Department 2, charging the 6% tax rate.

To add or force tax to a non-taxable department or a different tax rate

- 1 Press tax 1 .
- 2 Using the Number keys, press 100, and then press DEPT002 .
- 3 Press amount tender .

Active Table Pickup

Example 2: In Restaurant mode, to view active tables and pick up table 1.

To view an active table

- 1 If the clerk numbers are set, press the four digit passcode and then press

clerk .

- 2 Press **active table** .

- 3 Open a table by entering the table number and pressing **open table** .

Bill Print

Example 3: In Restaurant mode, print the bill for table 1 without closing the transaction.

To use the bill print feature (only in Restaurant mode)

- 1 Using the number keys press 01 and then press **open table** . The transaction details for table 01 appear.

- 2 Press **bill print** to print a copy of the bill.

Cash Sale With Tendering Change

Example 4: Ring up a \$1.00 item in Department 1 and compute change from \$5.00 cash tendered.

To ring up a sale with tendering change

- 1 Using the Number keys, press 100, and then press **DEPT001** .

- 2 Press **subtotal** ,

You do not need to press **subtotal** if you do not want the subtotal to be printed on the receipt.

- 3 Using the Number keys, press 500, and then press **amount tender** .

Cash Sale Without Tendering Change

Example 5: Ring up a \$1.00 item in Department 1.

To ring up a sale without tendering change

- 1 Using the Number keys, press 100, and then press **DEPT001** .

2 Press **subtotal** .

You do not need to press **subtotal** if you do not want the subtotal to be printed on the receipt.

3 Press **amount tender** .

Charge Sale

Example 6: Ring up a \$1.00 item in Department 1 and finalize the sale with the charge key.

To ring a charge sale

1 Using the Number keys, press 100, and then press **DEPT001** .

2 Press the **charge** key.

You do not have to enter any amounts before pressing **charge** unless you set the Compulsory Declaration to On.

Credit/Charge Refund

Example 7: Refund \$1.00 in Department 1 and credit the return to charge.

To ring a charge refund

1 Using the Number keys, press 100, and then press **refund** .

2 Press **charge** .

Check Sale

Example 8: Ring up a \$1.00 item in Department 1 and finalize the sale with the Check key.

To ring a check sale

1 Using the Number keys, press 100, and then press **DEPT001** .

2 Press **check** .

You do not have to enter any amount before pressing **check** unless you set the Compulsory Declaration to On.

Cooking Messages

You can use cooking messages in 2 ways: As programmed or manually entering during a transaction.

After entering a transaction with a cooking message, you see a message on the screen that says: “Send Successful”. This message lets you know that the backup printer received the cooking message.

Note



The cooking message feature is not available on all versions. Contact Royal for more information.

Using Preset Messages

This example assumes that cooking messages are enabled and message 01 is programmed with a message of “Rare”.



Example 9: Ring up an item for \$15.99 for Department 1 and then select the cooking message “01 Rare”.

To use a programmed cooking message

- 1 Using the Number keys, press 1599, and then press .
- 2 Press .
- 3 Using the Number keys, press 01 and then press .

Using Manual Messages

Example 10: Enter an item for \$4.99 for Department 1. Manually enter the cooking message “No tomato”.

- 1 Using the Number keys, press 499, and then press .
- 2 Press .
- 3 Using the Alpha screen, enter the message no tomato, and press .

Coupon Discount Sale

Example 11: Ring up a \$1.00 item and then apply a 20% (.20) off coupon.

To ring a coupon discount sale

- 1 Using the Number keys, press 100, and then press .

- 2 Using the Number keys, press 20 and then press **coupon** .
- 3 Press the **amount tender** key.

Sales tax is charged on the amount after the coupon is deducted. For more complex coupons, see Customer Service for help.

Credit Sale

Example 12: Ring up a \$1.00 item in Department 1 and \$2.00 in Department 2 and finalize the sale with the Credit key.

To ring a credit sale

- 1 Using the Number keys, press 100, and then press **DEPT001** .
- 2 Using the Number keys, press 200, and then press **DEPT002** .
- 3 Press **credit** .

Note

You do not have to enter an amount before pressing either of the credit keys unless you set the Compulsory Declaration to On.

Dept Shift Button and Departments above 40

Example 13: Ring up a \$1.00 item in Department 1 (taxable), \$2.00 in Department 21 (non-taxable) and \$3.00 in Department 70 and compute change from \$10.00 cash tendered.

Note

Departments 21 and 70 must be programmed.



To ring a sale using the Dept Shift key

- 1 Using the Number keys, press 100, and then press **DEPT001** .
- 2 Using the Number keys, press 200, then press **dept shift** , and then press **DEPT021** .
- 3 Using the Number keys, press 300, press **dept** , in the Number keys, press 70, and press **dept** .
- 4 Using the Number keys, press 1000, and then press **amount tender** .

Direct (Hard) PLUs

Example 14: Assume the PLUs for “Apple” and “Banana” are mapped to direct PLU keys. Ring a sale for 1 Apple and 1 Banana and finalize the sale with the **Check** key.



To use the direct (hard) PLU keys

- 1 Press  .
- 2 Use **Prev Page** or **Next Page** to switch between pages 1-11, select **Apple** and **Banana**.
- 3 Press  to return to the main sales screen.
- 4 Press  to finalize sale

Exempting Tax On An Item

Example 15: Assume the Department 1 key is programmed as a taxable department. Ring up a \$1.00 item in Department 1 without charging tax.





To ring an item without charging tax

- 1 Press  . The header updates to show the selection.
- 2 Using the Number keys, press 100, and then press  .
- 3 Press  .

Exempting Tax on the Entire Sale

Example 16: Assume the Department 1 key is programmed as a taxable department. Ring up a \$1.00 item and a \$1.50 item in Department 1 without charging tax.

To ring an entire sale without charging tax

- 1 Using the Number keys, press 100, and then press  .
- 2 Using the Number keys press 150, and then press  .
- 3 Press  .
- 4 Press  .

Note

After pressing **non tax**, you must end the sale. You cannot enter additional items to the transaction.

- 5 Press **amount tender**.

Foreign Currency Sale

Example 17: Assume that fc1 is set for "Pesos" and the current exchange rate is 10 Pesos per US dollar. Ring up a \$5.00 sale in department 1 and calculate the change from 100 pesos.

To use the fce (foreign currency) key

- 1 Using the Number keys press 500, and press **DEPT001**.
- 2 Press **fce**.
- 3 Using the pop-up box, select **Pesos**. The subtotal amount in the transaction box changes to 50.00.
- 4 Using the number keys press 10000, and press **amount tender**.

Gallonage Sales Transaction

Example 18: In this example, Department 4 is programmed for Gallonage Mode and is non-taxable. Ring 10.759 gallons at \$2.749 per gallon.

Note

Department 4 must be programmed as gallonage before you start.

To ring a gallonage sales transaction

- 1 Using the Number keys, press 10.759, and then press **x/time**.
- 2 Using the Number keys, press 2749, then press **DEPT002**.
- 3 Press **amount tender**.

Minus Percentage Discount Sale



Example 19: Apply a 10% discount on a \$1.00 sale in Department 1 using both a preset discount or by manually entering the discount.

To ring a minus percentage discount sale using a preset discount

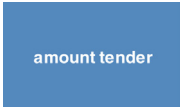
- 1 Using the Number keys press 100, and then press **DEPT001**.

- 2 Press  .
- 3 Select the discount you want to apply.
- 4 Press  .

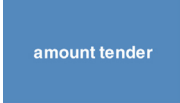

To ring a minus percentage discount sale with a 10% manual discount

- 1 Using the Number keys press 100, and then press  .
- 2 Enter 10 and press  .
- 3 Select the discount you want to use.
- 4 Press  .

Misc. Sale

Example 20: Ring in a \$1.00 sale in Department 1, using misc as the payment method.



To use the misc tender key

- 1 Using the number keys press 100, and press  .
- 2 Press  .

Multiplication of a Department Unit Price

Example 21: Assume the Department 1 key is pre-programmed for \$1.00. Ring up this price three times.

To multiply a department unit price

- 1 Using the Number keys, press 3, and then press  .
- 2 Press  .
- 3 Press  .



Note

You can ring up to 35 restaurant or 38 retail department presets by using the direct department keys.

Multiplication Sale and Overriding a Preset Department Price

Example 22: Ring up three \$4.00 items in Department 1, overriding the \$1.00 preprogrammed price.

To ring a multiplication sale

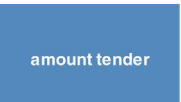
- 1 Using the Number keys, press 3, and then press .
- 2 Using the Number keys, press 400, and then press .
- 3 Press .

Note

You can use from .001 to 999.999 when ringing up the quantity of an item.



Multiplying By A Fraction

Example 23: Multiply the quantity of 1.25, as in 1¼ yards of fabric at \$1.00 per yard in Department 1.

Caution

When multiplying by a fraction, you must use the decimal point in the fraction but not in the dollar amount.

To multiply an item by a fraction

- 1 Using the Number keys, press 1 . 25, and then press .
- 2 Using the Number keys, press 100, and then press .

Note

You can use from .001 to 999.999 when ringing up the quantity of an item.

No-Sale Function (Opening the Cash Drawer)

Example 24: Open the drawer without ringing up a sale to give change.

To use the No Sale function

- ◆ Press . The cash register drawer opens.



Note

The number of times the No Sale key is used appears on the Management Reports. For more information about these reports, see Running Management Reports on page 83.

Opening and Closing Tables

Example 25: Open table 4, add a \$1.00 item for Department 1, and then close the table.

To open and close a table

- 1 Using the Number keys, press 4, and then press  .
- 2 Using the Number keys, press 100, and then press  .
- 3 Press  .

Paid-Out Sale

Example 26: Indicates money taken out of the cash drawer. Ring up \$10.00 to show money paid out of the cash drawer.

Note

You can pay out using cash, check, or misc, depending on your selection.

To record monies paid out

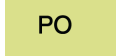
- 1 Using the Number keys, press 1000, then press  .
- 2 Select your method of payout (cash, check, or misc) to finalize.

PLU Sale

Example 27: Assume the PLU # is preset for the price of \$1.99 in Department 1. Ring up the PLU #1.

To ring a PLU sale

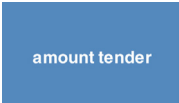
- 1 Using the Number keys, press 1, and then press the  key.
- 2 Press the  key.



Note

PLUs follow the same procedure for ringing up Coupons, Refunds, Minus Percentage Discounts, Plus Percentages, and so on, as with ringing these items up for a Dept # sale.

Plus Percentage Sale

Example 28: If no tax is programmed in your cash register, ring up a \$1.00 item in Department 2 and apply a pre-programmed Plus Percentage Rate of 10%.

To ring a PLU percentage sale

- 1 Using the Number keys, press 100, and then press .
- 2 Press  and select the correct discount.
- 3 Press .

Received-On-Account Sale

Example 29: Indicates money put in the cash drawer. Ring up \$50.00 to show the beginning cash-in-drawer amount for the day.

Tip

You can receive-on-account using cash, check, or misc.



To receive monies on account

- 1 Using the Number keys, press 5000, and then press .
- 2 Select the method of payment (cash, check, or misc) to finalize.

Registering a Department Unit Price

Example 30: Assume Department 1 is pre-programmed for \$1.00. Ring up this price.

To register a department unit price

- 1 Press .
- 2 Press .

Note

You can ring up to 35 restaurant or 38 retail department presets by using the direct department keys.



Registering a Reference Number/Message

Example 31: Used to print a number, up to 24 digits, to identify an invoice number or any other number on receipts. Ring up the number 1234567 in a standard sale. (Also, in Restaurant mode, use to manually enter a cooking message. See Using Manual Messages on page 107.)

Note

Using the reference number is not recorded in any activity counter or sales totals on the Management Reports.

To register a reference number

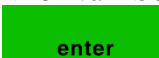
- 1 Using the Number keys, press 100, and then press  .
- 2 Press  .
- 3 Using the Number keys, enter the Reference Number 1234567, and press  .

Note







You can also enter an alphanumeric message using this screen.

- 4 Press  .

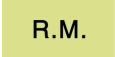
Return Sale

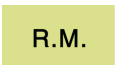
Example 32: Return a \$1.00 item in Department 1 and return a \$1.50 item three times in Department 1. If the Inventory function is turned on, the inventory levels for any returned PLUs are automatically adjusted.

To ring a return sale

- 1 Press  .
- 2 Using the Number keys, press 100, and then press  .
- 3 Press  .
- 4 Using the Number keys, press 3, and then press  .
- 5 Using the Number keys, press 150, and then press  .
- 6 Press  .

Note

The Return function can be performed in the middle of any sales transactions or by itself in a separate transaction.

Refunding Cash

Example 33: Refund a \$1.00 cash sale.

Note

You cannot perform a refund operation during a sales transaction. It must be performed as a separate action.

To ring a refund sale

1 Using the Number keys, press 100, and then press  .

2 Press  .

Split Tendering Sale

Example 34: Ring up a \$15.00 item in Department 1 with 6% sales tax, split the total of the sale between \$5.00 in cash payment and \$10.90 in charge payment.

To ring up a Split Tendering sale

1 Using the Number keys, press 1500, and then press  .

2 Press  .

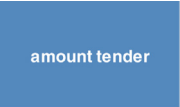
3 Using the Number keys, press 500, and then press  .

4 Press  .

Note

When using the Split Tendering function, you can finalize the sale with any separate form of payment. Substitute the desired key in Step 4 in the example above.

Transferring Tables

Example 35: Transfer the transaction details of table 4 to table 27.

To transfer a table

1 Press  .

2 Following the instructions on the screen and using the Number keys, enter 4, and then press  .

3 Following the instructions on the screen and using the Number keys, enter 27, and then press  .

4 A confirmation report is printed.





Using the Error-Correct /Void Button

Example 36: Ring up a \$1.00 item in Department 1, then use both the **E.C.** and **Void** keys (separately) to cancel this entry. Finally, ring up a \$10.00 item in Department 1 and end the sale.





Note

E.C. corrects the last entry rung up during a sale. Use **Void** to manually correct a price, department, or PLU entry.

To use the Error Correct (E.C.) key

- 1 Using the Number keys, press 100, and then press  .
- 2 Press  .
- 3 Using the Number keys, press 1000, and then press  .
- 4 Press  .





To use the Void key

- 1 Using the Number keys, press 100, and then press  .
- 2 Press  .
- 3 Using the Number keys, press 100, and then press  .
- 4 Using the Number keys, press 1000, and then press  .
- 5 Press  .

Voiding a Department Preset Price

Example 37: Department 1 is programmed for the price of \$1.00 and Department 2 is programmed for the price of \$2.00. Ring up Department 1 and Department 2 prices, then void the Department 1 entry.



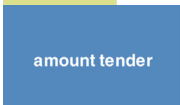



To void a department preset price

- 1 Press  .
- 2 Press  .
- 3 Press  and then press  .
- 4 Press  .

Voiding a Multiplication of a Department Preset Price

Example 38: Assume Department 1 is programmed for the price of \$1.00 and Department 2 is programmed for the price of \$2.00. Ring up Department 1 three times and Department 2 two times, then void the Department 1 entry rung up three times.

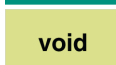

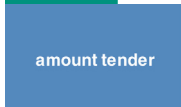
To void a multiplication of a department preset price

- 1 Using the Number keys, press 3 and then press  .
- 2 Press  .
- 3 Using the Number keys, press 2 and then press  .
- 4 Press  .
- 5 Press  .
- 6 Using the Number keys, press 3 and then press  .
- 7 Press  .
- 8 Press  .

Voiding a Department Multiplication Sale

Example 39: Void a \$1.00 item in Department 1 three times.

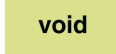

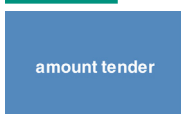
To void a department multiplication sale

- 1 Press  .
- 2 Using the Number keys, press 3 and then press  .
- 3 Press  .
- 4 Press  .

Voiding a PLU Sale

Example 40: Assume PLU #1 is preset for the price of \$1.00 in Department 1. Void PLU #1.

To void a PLU sale





- 1 Press  .
- 2 Using the Number keys, press 1, and then press  .

- 3 Press the  key.

Voiding a PLU Multiplication Sale

Example 41: Assume PLU #1 is preset for the price of \$1.00 in Department 1. Void PLU #1 three times.

To void a PLU multiplication sale

- 1 Press .
- 2 Using the Number keys, press 3, and then press , and then press 1.
- 3 Using the Number keys, press 1, and then press .
- 4 Press .





Voiding an Entire Sale before Finishing the Sale

Example 42: Void an entire sale before you press the **Amount Tender** key. Void a sale for a \$1.00 item in Department 1, a \$2.00 item in Department 2, a \$3.00 item in Department 4.

Note

Use to correct any coupon or discount/add-on transactions.

To void an entire sale

- 1 Using the Number keys, press 100, and then press .
- 2 Using the Number keys, press 200, and then press .
- 3 Using the Number keys, press 300, and then press .
- 4 Press .

Voiding a Sale

Example 43: Void a \$1.00 item in Department 1.

Note

Use this method to also void a coupon or discount sale.

To void a sale that is already completed

- 1 Press .

2 Using the Number keys, press 100, and then press .

3 Press .



Product Information

Specifications and Safety

Table 11 Specifications And Safety

Feature	Description
Type	Electronic cash register
Displays	9 inch color touch screen LCD clerk display 1 line 10 digit numeric VFD display
Printer	57mm alphanumeric thermal printer.
Ink Source	Thermal printer - no ribbon or ink needed
Paper Supply	2¼ inch or 57.5 mm wide standard thermal paper (Royal Reorder # 013127)
Memory Battery Protection	Roughly 2 months after power interruption
Technology	CMOS RAM
Electrical Characteristics	115V ~ 60Hz, 0.40A
Operating Temperature	0-40 Degrees Centigrade (32-104 Degrees Fahrenheit)
Dimensions	13.8"W x 16.1"D x 13"H (with drawer)
Weight	26 lbs. (11.8 kg including printer)

Safety and Legal Notices

- The power outlet for this cash register must be located near the unit and be easily accessible.
- Do not use this cash register outdoors in the rain or near any source of liquid, such as a pool.

FEDERAL COMMUNICATIONS COMMISSION (FCC) RADIO FREQUENCY INTERFERENCE STATEMENT INFORMATION TO THE USER

CAUTION: Changes or modifications to this unit not expressly approved by the party responsible for compliance could void the user's authority to operate the equipment.

NOTE: This equipment has been tested and found to comply with the limits for a Class B digital device, pursuant to Part 15 of the FCC Rules. These limits are designed to provide reasonable protection against harmful interference in a residential installation. This equipment generates, uses and can radiate radio frequency energy and, if not installed and used in accordance with the instructions, may cause harmful interference to radio communications. However, there is no guarantee that interference will not occur in a particular installation. If this equipment does cause harmful interference to radio or television reception, which can be determined by turning the equipment off and on, the user is encouraged to try to correct the interference by one or more of the following measures:

1. Reorient or relocate the receiving antenna.
2. Increase the separation between the equipment and receiver.
3. If applicable, connect the equipment into an outlet on a circuit different from that to which the receiver is connected.

Consult the dealer or an experienced radio / TV technician for assistance.

Connection of peripherals to this unit requires the use of grounded, shielded cables to ensure compliance with the Class B FCC limits.

IN CANADA:

This digital apparatus does not exceed the Class limits for radio noise emissions from digital apparatuses set forth in the Radio Interference Regulations of the Canadian Department of Communications.

CAUTIONS AND WARNINGS

- Should the cash register malfunction, start to emit smoke or a strange odor, or otherwise behave abnormally, immediately shut down the power and unplug the AC plug from the power outlet. Continued use creates the danger of fire and electric shock. Contact a Royal service representative.
- Do not place containers of liquids near the cash register and do not allow any foreign matter to get into it. Should water or other foreign matter get into the cash register, immediately shut down the power and unplug the AC plug from the power outlet. Continued use creates the danger of shorting, fire and electric shock.

-
- Should you drop the cash register and damage it, immediately shut down the power and unplug the AC plug from the power outlet. Continued use creates the danger of shorting, fire and electric shock.
 - Attempting to repair the cash register yourself is extremely dangerous. Contact a Royal service representative. Never try to take the cash register apart or modify it in any way. Contact a Royal service representative for all repair and maintenance.
 - High-voltage components inside the cash register create the danger of fire and electric shock.
 - Use only a proper AC electric outlet (100V-240V). Using an outlet with a different voltage from the rating creates the danger of malfunction, fire, and electric shock. Overloading an electric outlet creates the danger of overheating and fire.
 - Make sure the power plug is inserted as far as it will go. Loose plugs create the danger of electric shock, overheating, and fire. Do not use the cash register if the plug is damaged. Never connect to a power outlet that is loose.
 - Use a dry cloth to periodically wipe off any dust built up on the prongs of the plug. Humidity can cause-poor insulation and create the danger of electric shock and fire if dust stays on the prongs.
 - Do not allow the power cord or plug to become damaged, and never try to modify them in any way. Continued use of a damaged power cord can cause deterioration of the insulation, exposure of internal wiring, and shorting, creating the danger of electric shock and fire. Contact a Royal service representative if the power cord or plug requires repair or maintenance

Caution

RISK OF EXPLOSION IF BATTERY IS REPLACED BY AN INCORRECT TYPE

- The battery should only be replaced by a certified technician at an authorized service center.
- Replace only with the same type of battery recommended by the manufacturer.
- Properly dispose of all used batteries according to the battery manufacturer's instructions or according to your local environmental regulations and disposal guidelines.
- **Never** dispose of any batteries in fire! The batteries may leak or explode.
- The back-up power system: When you are not using your cash register, keep it plugged in with the cash register turned OFF. If the unit is unplugged, back-up power for the memory is provided through the

battery, but this should not be used for long periods of time, as it may affect overall battery life.

Proposition 65 Notice

The following is given in accordance with California Proposition 65.

WARNING: This product contains chemicals known to the State of California to cause cancer, birth defects, or other reproductive harm.
Wash hands after handling.

Trademark Notice

All trademarks, registered trademarks and service marks mentioned in this manual and with this product are for identification purposes only and are the property of their respective holders.

Copyright

© 2007 by Royal Consumer Information Products, Inc.

Software Licensing Agreement

TERMS. The product which you have purchased from Royal contains software (“the Software”) which is owned by Royal and/or third parties which have provided the same to Royal and which is protected by the United States copyright laws and treaty provisions. By purchasing this product containing the Software, you are agreeing to be bound by the terms of this license. If you do not agree to this license, you must not use the product but rather immediately return it to your point of purchase for a full refund. Any such return must be made within any applicable time period established for returns at the point of purchase, but in no event later than 30 days after purchase. Your use of the product shall be deemed acceptance of this license.

GRANT OF LICENSE. With the purchase of your product from Royal, Royal grants you the right to use the Software, which is contained in the product. This grant is only for the specific person, which has purchased the product. In other words, the license, which accompanies each product, is only for one person.

RESTRICTIONS. You may not copy the Software, decompile it, duplicate it, modify it or reverse engineer it in any fashion.

RIGHTS. The Software is provided to you in an “as is” condition by Royal. **ROYAL MAKES NO WARRANTY WHATSOEVER WITH RESPECT TO THE SOFTWARE AND ALL EXPRESS OR IMPLIED WARRANTIES, INCLUDING ANY IMPLIED WARRANTY OF MERCHANTABILITY, FITNESS FOR A PARTICULAR PURPOSE OR NON-INFRINGEMENT, ARE SPECIFICALLY DISCLAIMED.** All other rights with respect to the Software, except as set forth in this license, are specifically retained by Royal or the owner of the Software. Nothing in this license constitutes a waiver of any rights Royal or the owners of the Software may have under any applicable copyright law or any other United States federal or state law.

GOVERNING LAW. This license is governed by the laws of the State of New Jersey.

Manufacturer's Limited Warranty

ROYAL ELECTRONIC CASH REGISTER AND TIME CLOCK LIMITED WARRANTY

Royal Consumer Information Products, Inc. ("Royal") at 379 Campus Drive, 2nd Floor, in Somerset, NJ 08875 USA warrants that your NEW Royal Electronic Cash Register or Time Clock ("Product") is free of defects of workmanship and materials. If there is a defect or malfunction of this Product, Royal will repair the Product free of charge as follows:

PARTS: New or comparable rebuilt parts in exchange for defective parts for ONE YEAR from the date of purchase.

LABOR: All labor charges incurred from a Royal Authorized Service Center or the Royal Corporate Service Center are covered for 90 DAYS from the date of purchase. After 90 days there will be a labor charge for repair of the Product and/or assemblies such as the touch screen, display(s), logic board, power supply and printer(s) at the Royal Corporate Service Center's or the Royal Authorized Service Center's then prevailing rates. The Product must be brought to a Royal Authorized Service Center nearest to your location; or the Product must be shipped postage prepaid, insured and via a traceable shipping method to a Royal Authorized Service Center or to the Royal Corporate Service Center. Royal will pay return postage from the Royal Corporate Service Center during the labor warranty period only.

This warranty does not apply to persons who purchased this Product second hand or used.

This warranty does not include the replacement of ink rolls, ribbons, time cards, paper rolls or any other consumable or supplies used in the cash register or time clock and consumed through the normal use of the Product.

This warranty does not include cleaning, adjustments, parts, or repairs required by circumstances beyond the control of Royal, including, but not limited to, fire or other casualty, accident, neglect, abuse, abnormal use, misuse or battery leakage damages. **THERE ARE NO OTHER EXPRESSED WARRANTIES EXCEPT AS STATED HEREIN. AFTER THE PERIOD OF EXPRESSED WARRANTY SET FORTH HEREIN, THERE ARE NO EXPRESSED OR IMPLIED WARRANTIES AND THOSE EXCLUDED INCLUDE THOSE OF MERCHANTABILITY AND FITNESS FOR A PARTICULAR PURPOSE.** Royal shall NOT be liable for **CONSEQUENTIAL DAMAGES** resulting from any failure, defect, or malfunction of this Product. Some states do not allow limitations on how long an implied warranty lasts and some states do not allow the exclusion or limitation of incidental or consequential damages, so the above limitations or exclusions may not apply to you.

TO OBTAIN SERVICE UNDER THE TERMS OF THIS WARRANTY:

- Pack your Product in the original carton or equivalent.
- Enclose a copy of the bill of sale or other documentation showing original purchase date.
- Enclose a card or note describing the difficulty you have had with the Product.
- Be sure to include your complete name, address and day-time telephone number.
- Bring or ship, prepaid and insured, via a traceable shipping method the above Product to the nearest Royal Authorized Service Center location or to the Royal Corporate

Service Center. Royal and/or the Service Center cannot be held responsible for any loss or damage that occurs while in transit.

For Authorized Service Centers within your local area, call 1-888-261-3888 or 1-800-272-6229. In Canada call 1-888-266-9380. Or you can call the Royal Corporate Service Center directly at 1-630-315-2603 for shipping instructions and additional information.

Please retain the original proof of purchase for your records to establish date of original purchase. Your warranty starts with the date of original purchase. This warranty gives you specific legal rights, and you may also have other rights which vary from State to State.

This warranty is valid only on cash registers and time clocks purchased, delivered and used in the United States and/or Canada.



Ordering Supplies and Accessories

Item	Part Number
Cash register control key set	W316-003-01(ROHS)
Duplicate Cash Drawer Key	RM-LOCK-013
Dust Cover	TE-01P-MA040
Kitchen Printer	Call Royal
Kitchen Printer Cable	Call Royal
Model PS700 Barcode Reader	16881W
Owner's Manual	TS4240IM0407A
RegisterLink PC-based software, replacement	RLNC
RegisterLink serial cable, replacement	WI-TE-01P-011
Replacement 4 Slot Bill Tray (Coin Tray not included)	SB-01C-UNIT-001
Replacement 5 Slot Coin Tray	SB-01C-RE-001
Thermal Register Tape (3-roll package) 2¼" (57mm) wide, 2" (50mm) diameter, 85' (26m) long	013127
USB-to-Serial Adapter, for connecting the cash register to a USB port on your PC	29249N

For Prices and Availability

Call 1-888-261-4555 or visit our web site at www.royal.com.

Prices and Availability Subject to Change Without Notice

Index

A

about

- management reports 83
- serial ports 92
- the battery 94
- X readings 83
- Z readings 85

accessories, ordering 127

adding tax to a non taxable department, example 104

additional printers, setting 37

age verification 36

amount tendered 53

B

barcode reader

- connecting 92
- programming PLUs 40
- purchasing 127
- ringing up sales 64
- setting up PLUs 40

battery, about 94

before going to register mode 42

bill, printing 67

C

Canadian tax rates 79

Canadian, tax system 73

canceling reports 81, 86

cash

- in drawer report 85, 87
- sale with tendering change, example 105
- sale without tendering change, example 105

cash drawer

- closing 18
- opening 18
- using 10

cash in drawer limit, setting 58

cash register turns off 96

change 53

changing tax rates 72

charge sale, example 106

checking the Electronic Journal memory status 89

C-I-D report 85, 87

cleaning the touch screen 91

clearing errors 43

clearing errors, about 43

clerk

- names, setting 28
- screen, adjusting 12
- system 28

system, using 30

clerk numbers

- setting 28
- using 30

clerk passcode, lost passcode 31

clerk setting report

- printing 82
- running 82

closing tables 68

closing, cash drawer 18

codes, transaction 103

common error messages 99

complex tax rates 72

confirming your settings 42

connecting

- a PC 93
- barcode reader 92
- receipt printer 92

contacting Royal 2

cooking messages, manually adding 67

coupon discount sale, example 107

coupon sale, voiding 119

coupon, setting 57

credit buttons, programming 37

credit, sale, example 108

currency

- receiving foreign 58
- setting up for foreign 58

- customer display
 - closing 11
 - opening 11

- customer service, contacting 2

D

- date, setting 55

- default languages, specifying 55

- delete entire transactions 43

- deleting PLUs 41

- department

 - keys, programming 32

 - number keys, using 34

 - preset price, programming 35

- departments, groups of 35

- dept shift key, example 108

- direct PLU numbers, using 63

- discount sale, voiding 119

- discount, setting 57

- display messages, changing
 - languages 5

- double wide characters

 - programming 24

 - receipts 24

E

- editing PLUs 41

- EJ reports, running 88

- Electronic Journal

 - checking memory status 89

 - reports 88

- ending tables 68

- error messages, common 99

- error, Paper end 95

- errors, clearing 43

- example

 - adding tax to a non taxable department 104

 - cash sale with tendering change 105

 - cash sale without tendering change 105

 - charge sale 106

 - coupon discount sale 107

- credit sale 108

- dept shift key 108

- exempting tax on an item 109

- exempting tax on the entire sale 109

- gallonge sales transaction 110

- minus percentage discount sale 110

- multiplication of a department
 - unit price 111

- multiplication sale 112

- multiplying by a fraction 112

- no-sale function 112

- paid-out sale 113

- PLU sale 113

- PLUs percentage sale 114

- registering a department unit
 - price 114

- registering a reference number 115

- return sale 115

- split tendering sale 116

- tax chart 77

- using error-correct (void) key 117

- voiding a department
 - multiplication sale 118

- voiding a department preset
 - price 117

- voiding a multiplication of a department preset
 - price 118

- voiding a PLU multiplication sale 119

- voiding a PLU sale 118

- voiding a sale 119

- voiding an entire sale before finishing the sale 119

- example receipt 104

- exempting tax on
 - an item, example 109

- the entire sale, example 109

F

- FCC warning 122

- finishing tables 68

- footer message

 - double wide 24

- programming 25

- setting 26

- worksheet 25

- foreign currency

 - receiving 58

 - setting up for 58

 - using 58

- full report, example 86

G

- gallonge sales transaction,
 - example 110

- getting help 2

- groups, setting 35

H

- happy hour

 - about 22

 - settings 46

- hard PLU keys 63

- HDLO 34

- header message

 - double wide characters 24

 - programming 25

 - setting 26

 - worksheet 25

- high digit lock out, setting 34

I

- inventory

 - on-hand count 38

 - safety margin count 39

 - setting 53

- items in receipts 104

K

- knowing how much change to give the customer 53

- KP printer, setting 37

L

- languages 5

 - initial setting 5

 - setting 5, 55

 - specifying default 55

- location of keys 13

- logos, picture logos on receipts 27

lost passcode 31

M

management reports, about 83
 manager passcode, lost passcode 31
 manager, passcodes, setting 30
 master clerk passcode 31
 master passcode 31
 master reset, about 43
 master reset, troubleshooting 98
 maximum PLUs allowed 38
 messages, setting footer and header 26
 minus percentage discount sale, example 110
 Mode key area, using 11
 multiple currencies 58
 multiplication
 of a department unit price, example 111
 sale, example 112
 multiplying by a fraction, example 112

N

no-sale function, example 112

O

on-hand count, inventory 38
 opening, cash drawer 18
 Options Dump report 56
 ordering
 accessories 127
 more register tape 127
 supplies 2

P

paid-out sale, example 113
 Paper end error 95
 partial rest, performing 98
 parts, ordering 127
 passcodes
 clerk, setting 28
 lost 31
 manager 30

setting manager 30
 setting X 30
 super clerk 31
 super manager 31

picture logos, printing on receipts 27

piggy back tax 79

PLU

deleting 41
 description, programming 38
 programming 38
 sale, example 113
 total number allowed 38

PLUs

editing 41

PLUs percentage sale, example 114

PLUs, programming the barcode reader 40

position of logos, specifying 27

printer, additional 37

printing

receipt on demand 65
 receipts 64

printing the bill 67

program confirmation report, printing 42

programming

clerk numbers 28
 credit buttons 37
 department keys 32
 department preset price 35
 double wide characters 24
 footer messages 25
 header messages 25
 high digit lock-out (HDLO) 34
 manager passcode 30
 PLU description 38
 PLUs with the barcode reader 40
 tax rates 72
 tax status 35

Proposition 65 warning 124

R

receipt
 example 104
 items described 104

printer, connecting 92

printing, errors 95

receipt messages, setting 26, 49

receipt on demand 65

receipt, picture logos 27

receipts

printing 64

register

does not work, troubleshooting 97

tape, ordering replacement 127

register mode, before going to 42

registering a

department unit price, example 114

reference number, example 115

RegisterLink

software 8

using 93

replacement register tape 127

reports

about 83

canceling 81, 86

C-I-D 85, 87

clerk setting 82

confirmation 82

EJ reports 88

Electronic Journal 88

example 86

management 83

program confirmation 42

running 86

reports, Options Dump 56

reports, restaurant-specific 46

restaurant-specific reports 46

return sale, example 115

ringing up

direct PLU keys 63

sales 62

sales, barcode reader 64

Royal, contacting 2

running

Electronic Journal reports 88

management reports 83

PLU confirmation reports 82

reports 86

S

safety
margin, inventory 39
notice 122
scanning items 64
serial ports
about 92
setting
alphanumeric descriptions 23
clerk names 28
clerk numbers 28
footer and header messages 26
languages 5
machine numbers 32
manager passcodes 30
standard or gallonage mode 35
tax rates 72
times for happy hour 46
up, barcode reader 40
X passcodes 30
settings, confirming 42
software
for PCs 8
licensing agreement 124
RegisterLink 8
special instructions, manually
adding 67
specifying tax rates 72
split tendering sale, example 116
stop printing reports 81, 86
super clerk passcode 31
super manager passcode 31
supplies, ordering 2

T

tables
closing 68
ending 68
finishing 68
tax

piggy back 79
tax-on-tax 79
worksheet 78
tax chart, example 77
tax limits 74
tax rates
Canadian 73, 79
setting 72
VAT 73
tax system, setting 55
tax, status, programming 35
tax-on-tax, setting 79
technical information, serial ports
92
time format, setting 55
time, setting 55
total number allowed, PLUs 38
touch screen
cleaning 91
using 13
training mode
setting passcode 69
using 68
transaction codes 103
troubleshooting 95
master reset 98
performing a partial rest 98
register does not work 97
turn the cash register
off 10
on 10

U

using
cash drawer 10
clerk system 30
department number keys 34
double wide characters 24
error-correct (void) key,
example 117

Mode key area 11
touch screen 13
training mode 68

V

VAT tax system 73
verifying ages during a sale 36
void a sale 43
voiding
an entire sale before finishing
the sale, example 119
coupon sale 119
department multiplication sale
example 118
department preset price
example 117
discount sale 119
multiplication of a department
preset price example 118
PLU multiplication sale
example 119
PLU sale example 118
sale example 119

W

warning
FCC 122
Proposition 65 124
warranty 125
worksheet
footer message 25
header message 25
table tax 78

X

X passcodes, setting 30
X readings, about 83

Z

Z readings, about 85